

p-u-l-s-o-t-r-o-n-i-c

ANLAGENTECHNIK

PRODUCT CATALOG

Issue: 1101





Pulsotronic-Anlagentechnik GmbH has its registered offices in the Chemnitz-Zwickau business area of Niederdorf/Stollberg. Because of the permanent, positive development of the business, a new complex of buildings was erected in 2007 directly on the A72. The structural facts, latest production equipment and a motivated work force permit a top-flight degree of innovation and flexibility.

Pulsotronic develops, produces and sells metal detectors, separators and custom equipment based on many years of experience in the plastics and recycling industry. Further innovative products were successfully introduced in the food industry and in other branches of industry.

Our products distinguish themselves through their high reliability, sensitivity and user-friendliness. A team of engineers permanently works on improvements and customer-specific solutions.

The development and production of all the products and custom systems occurs completely at the site in Niederdorf. Thus, it is possible for us to try out new processes and principles and to put them into practice as quickly as possible.

In addition, we utilize the synergies of our Group of Companies. We are able to access all the areas quickly, thereby ensuring our flexibility, regardless of whether this involves our high efficient toolmaker's shop, plastic transfer molding, electronic fabrication or EMC laboratory.

Quality assurance and environmental protection are central components of Management. Pulsotronic-Anlagentechnik has been ISO 9001 certified since 2001. The initial certification of the Environmental Management System in accordance with ISO 14001:2004 took place in 2007.

Are you unable to find the product you require in the catalog?

Do you require a custom solution?

Do you have any questions or suggestions?

Our sales engineers are happy to advise you on site.



Extensive technical knowledge and outstanding on-site service belong to the basic prerequisites for a successful machinery and systems business. We would be pleased to tackle your tasks, while remaining loyal to our motto:

„Pulsotronic - complex solutions from one source“



We assume no guarantee for misprints.

Product selector.....	1.4
Application notes.....	1.6
Choosing the right detector.....	1.6
Finding the right place of installation.....	1.7
Which sensitivity.....	1.7
How to determine the sensitivity.....	1.8
What does product effect mean.....	1.8
Application in the food industry.....	1.9
Imprint.....	1.9
Certificate/Declaration of conformity.....	1.10
Control units.....	2.1
Overview.....	2.1
M-Pulse Control.....	2.3
M-Pulse.....	2.7
Digital+.....	2.11
MESEP.....	2.15
Sensors.....	3.1
Flat sensors.....	3.1
MESEP AR.....	3.1
MESEP FS.....	3.5
MESEP SP.....	3.9
MESEP RE.....	3.13
Series FL.....	3.17
Tunnel sensors.....	3.19
Series BD.....	3.19
Series BD-SL.....	3.23
Series TU.....	3.27
Ring sensors.....	3.31
Series KJR.....	3.31
Series RG.....	3.45
Series KS.....	3.47
Accessories.....	3.51
Control unit for ring sensors (KJR).....	3.51
Control unit for flat sensors (AR; FS; RE; SP).....	3.53
Control unit for flat sensors 10-fold (AR; FS; RE; SP).....	3.55
Separators for bulk solids.....	4.1
Series Extraktor.....	4.1
Series GF.....	4.5
Series GFC.....	4.9
Series VA.....	4.13
Series Y.....	4.17
Series SE.....	4.21
Series Classic.....	4.25
Series PH.....	4.27
Separators für liquids and paste-like products.....	5.1
Series InLine.....	5.1
Series InFlex.....	5.5
Separators with conveyor for single piece goods and bulk solids.....	6.1
Conveyor HQ+detector M-Pulse.....	6.1
Terms and condition.....	7.2



Product selector

Industry	Kind of product	
Food	Piece goods	
	Liquids & paste-like products	
	Bulk solids (free falling & free flowing)	
Plastic	Piece goods	
	Bulk solids (free falling & free flowing)	
	Bulk solids (free falling or pond)	
	Bulk solids (vacuum transported)	
	Foil (or other plastic yard ware)	
Pharmaceutics	Pills	
Recycling	Inspection goods on conveyor	
	Bulk solids	
Chemical	Liquids	
Textil	Drapery (or other yard ware)	
Wood & paper	Raw wood; boles	
	Shelves & flak boards	
	Paper	
	Bulk solids (sawdust; wood snippets)	

If your branche is not listed or if you need any help choosing the right product for your application, please feel free to contact our service staff or our foreign distributors.



p-u-l-s-o-t-r-o-n-i-c

Product selector

	Complete assembly		Single sensors	
	Conveyor HQ with detector M-Pulse	p. 6.1	Tunnel detector BD	p. 3.19
			Tunnel detector BD-SL	p. 3.23
			Tunnel detector TU	p. 3.27
	InLine	p. 5.1	Ring sensor RG	p. 3.45
	InFlex	p. 5.5	Ring sensor KJR	p. 3.31
	GF	p. 4.5	Ring sensor RG	p. 3.45
	GFC	p. 4.9	Ring sensor KJR	p. 3.31
	VA	p. 4.13		
	Conveyor HQ with detector M-Pulse	p. 6.1	Tunnel detector BD	p. 3.19
			Tunnel detector BD-SL	p. 3.23
			Tunnel detector TU	p. 3.27
	GF	p. 4.5	Ring sensor RG	p. 3.45
	GFC	p. 4.9	Ring sensor KJR	p. 3.31
	VA	p. 4.13	Ring sensor KS	p. 3.47
	SE	p. 4.21		
	Classic	p. 4.25		
	Y	p. 4.17		
	Extraktor	p. 4.1		
			Flat sensor FL	p. 3.17
			MESEP AR / RE / SP	p. 3.1
	VA	p. 4.13	Ring sensor RG	p. 3.45
	PH	p. 4.27	Ring sensor KJR	p. 3.31
			Tunnel detector TU	p. 3.27
			Flat sensor FL	p. 3.17
			Flat sensor FS	p. 3.5
	GF	p. 4.5	Ring sensor KJR	p. 3.31
	GFC	p. 4.9	Ring sensor KS	p. 3.47
			Flat sensor FS	p. 3.5
	InLine	p. 5.1	Ring sensor RG	p. 3.45
			Ring sensor KJR	p. 3.31
			Flat sensor FL	p. 3.17
			MESEP AR / RE / SP	p. 3.1
			Flat sensor FL	p. 3.17
			MESEP AR / RE / SP	p. 3.1
			Flat sensor FL	p. 3.17
			MESEP AR / RE / SP	p. 3.1
	GF	p. 4.5	Ring sensor KJR	p. 3.31
	GFC	p. 4.9		



Application of metal detectors

Metal detectors are used for various applications in industry. Classic fields of application are machine protection (damage on tools, mills, automats etc. caused by metallic pieces), object counting or sensing in automated manufacturing. The use for quality control processes is gaining more and more importance for example in the plastics industry (control of purity of materials and products), in the food industry (consumer protection) or in the pharmaceutical industry. We provide the appropriate solution for each application. In order to achieve optimum results using a metal detector there are facts that should be considered previous to the use of the device. Especially high-sensitivity sensors have to be applied accurately to tap their full potential. Please take into account the following information so that you can work efficiently with our devices right from the beginning. If there are any questions left unanswered, please contact our sales engineers. They will be at your disposal - on-site if necessary. For difficult applications it is possible to use machines on hire in order to collect and to take into account important criteria previous to purchase.

Choosing the right detector

There are various characteristics qualifying each type of metal detector for specific applications. The principal characteristics at a glance:

- 1. Dimension:** The sensor should be adapted to the size of the product. If the detector is too large, this causes a loss of sensitivity. For each of our series we provide different dimensions. If the right dimension for your applications is not mentioned in the catalogue we are at your disposal. Please contact our sales department or our distributors.
- 2. Sensitivity:** Please choose the sensitivity on the criterion of the expected contamination. A too little sensitivity causes deficient results. Devices with a very high sensitivity generally are more expensive and more difficult to handle. Just choose the right operating electronics from our modular design system. Data concerning the sensitivity are given on each data sheet.
- 3. Equipment:** If you require special features - no problem. Additional to various operating electronics we offer a wide range of accessories. On request we also realise customised solutions.
- 4. Design:** Along with the dimension of the device characteristics as the operating temperature, the protection class and the material are of great importance. Sensors are available in all possible protection classes as well as in various materials. Especially for applications in the food industry or in other branches requiring high hygienic standards we provide sensors and devices in stainless steel or in food safe plastic. Please consider these facts and try to fix your requirements in the run-up in order to choose the right device.



Finding the right place of installation

Beside the selection of the appropriate device the choice of the right place of installation is of great importance. Please inspect carefully where pollution can emerge, where people can be injured or machines damaged and where contaminated or faulty material can be locked out efficiently. In many cases the use of several metal detectors is reasonable. Furthermore please pay attention to the fact that metal detectors sensitively react on external interferences. For this reason our metal detectors are checked on their interference susceptibility in our in-house EMC-laboratory. Within the CE-declaration of conformity these values are complemented by external testing laboratories and laboratories accredited from the Technical Control Board. If necessary we will give advice to you for finding the right place of installation.

Which sensitivity?

Contrary to many of our competitors we provide precise information concerning the sensitivity of all of our devices. We know about the high-capacity of our products and we take practical values as a basis, that cannot only be achieved in a laboratory but also in the real application. Each device passes several tests previous to the delivery in which all parameters are collected and checked. The constancy of our production is guaranteed by ISO 9001. Thus not reliable data and bad surprises are impossible. Please check carefully which values are presented to you. If you want to we will check your product gratis in advance in our headquarters. By this you receive precise information concerning the sensitivity.

In practice a reduction of the sensitivity can be caused by:

- vibrations
- the product effect
- electromagnetic pollution
- the place or the position of installation

Our detectors are equipped with features restraining interferences. This allows application also under difficult conditions. Nevertheless our sensors are subject to physical barriers and will be influenced negatively by strong interferences as above mentioned.



How to determine the sensitivity

The sensitivities stated in this catalogue respectively in the data sheets have been measured under the following conditions:

- The device is switched-on for at least 5 minutes.
- The ambient temperature is at 20 .. 25°C.
- There is no interference caused by electromagnetic fields.
- There is no interference caused by mechanical vibrations.
- The vibration filters of the operating electronics are deactivated.
- The sensitivity test is effected using certified test objects. The test objects are either ferrous, non-ferrous (brass) or made of stainless steel 316.
- The smallest available dimensions of these test objects are: ferrous objects 0,3 mm, non-ferrous objects 0,3 mm and stainless steel objects 0,5 mm. The test objects are not available in all in-between sizes. That is why certain data has been determined arithmetically and can be verified using the nearest big test object size available.
- For the sensitivity test the test objects are always led centrally (most unfavourable position) through the sensor.
- For downstream sensors and extractors the test velocity is at 3000 mm/s. The fall height for downstream sensors is at maximum 0,6 m. The test velocity for conveyor detectors is at 300 mm/s. Inline and Inflex sensors are tested at 500 mm/s.

What does product effect mean?

The working principle of metal detectors generally is based on sensors with one or several coils. These coils excite electromagnetic fields. By this fields products are tested on metallic residua. Metal changes the electromagnetic field e.g. in its shape or it attenuates the field (it withdraws energy from the field). These effects are registered and analysed by the operating electronics. Anyhow not only metallic objects can influence electromagnetic fields. Conductive materials or materials with certain dielectric characteristics cause similar effects as a piece of metal. This so-called product effect excites an alarm for the detection of metal although there is no metal contained in the product. There are two possibilities for avoiding this effect:

1. Reduce the sensitivity until there are no more faulty alarms:
Advantage: cost-effective
Disadvantage: high loss of sensitivity
2. Multi-coil-system with digital evaluation for product effect elimination
Advantage: Minimum loss or no loss of sensitivity

With our M-PULSE and Digital+ we offer two high-capacity electronics with precise fade-out of the product effect. The M-PULSE electronics is able to collect and save several product adjustments



as well as the information concerning the product effect. This data are memorised in the device (memory capacity for 199 products) and recallable if necessary. The data also can be transferred to a pc, adapted, re-transferred or archived via network. The smaller Digital+ electronics represents the connection between high-end devices and standard devices. Due to the attractive price and the easy handling customers can now profit from modern electronics with fade-out of the product effect also for simple and cost-sensitive applications.

Application in the food industry

Many of our devices are used in the food industry. The compliance with legal restraints and requirements of the markets concerning the adherence with several quality standards (IFS; HACCP; ISO; FDA) is no problem due to our M-PULSE electronics with logging and cross-linking. Thus all data can be collected, processed and archived completely and centrally. Many series are made of stainless steel or food safe plastic. Furthermore most devices are available in protection class IP65 or higher. This makes cleaning easy.

Imprint

Company: Pulsotronic-Anlagentechnik GmbH
Neue Schichtstraße 7
D - 09366 Niederdorf

Phone: +49 37296 9383-500
Fax: +49 37296 9383-501
Email: info@pulsotronic-anlagentechnik.de
www: <http://www.pulsotronic-anlagentechnik.de>

General Manager: Martin Schweitzer
Authorized Manager: Matthias Kutz
Register court: Chemnitz
HRB 23031

VAT Reg. No.: DE250363291
Tax office: Stollberg
Tax number: 224/116/03052



p-u-l-s-o-t-r-o-n-i-c



Management Service

CERTIFICATE

The Certification Body
of TÜV SÜD Management Service GmbH
certifies that

Pulsotronic GmbH & Co. KG
Neue Schichtstraße 14
D-09366 Niederdorf

has established and applies
a Quality Management System for

**Development, production, distribution and service of
electronic components, proximity switches, foreign body
detection and separating systems and combined with
customers applications, image processing systems
and their components for industrial use**

An audit was performed, Report No. **70029415**
Proof has been furnished that the requirements
according to

ISO 9001: 2008

and of international and German
Road Traffic Law have been satisfied.

(Production sites and scope of application see enclosure, 1 page)

The certificate is valid until **2012-06-07**

Certificate Registration No. **12 102 16905 TMS**

Munich, 2009-08-05

Page 1 of 2



KBA-ZM-A22001-95



TÜV SÜD Management Service GmbH • Zertifizierstelle • Ridlerstraße 65 • 80339 München • Germany

ISO - certificate

ZERTIFIKAT ♦ CERTIFICATE ♦ 認証書 ♦ СЕРТИФИКАТ ♦ CERTIFICADO ♦ CERTIFICAT

MS01/007

1.10

Pulsotronic-Anlagentechnik
GmbH

Neue Schichtstraße 7
D-09366 Niederdorf

Tel.: +49 37296 9383-500
Fax: +49 37296 9383-501

info@pulsotronic-anlagentechnik.de
www.pulsotronic-anlagentechnik.de



ZERTIFIKAT ♦ CERTIFICATE ♦ CERTIFICADO ♦ CERTIFICAT ♦ СЕРТИФИКАТ ♦ 認証書 ♦ CERTIFICATE ♦ ZERTIFIKAT ♦ CERTIFICADO ♦ CERTIFICAT



Management Service

CERTIFICATE

The Certification Body
of TÜV SÜD Management Service GmbH
certifies that

Pulsotronic GmbH & Co. KG
Pulsotronic-Anlagentechnik GmbH
Neue Schichtstraße 14
D-09366 Niederdorf

has established and applies
an Environmental Management System for

**Development, production, distribution and service of
electronic components, proximity switches, foreign body detection
and separating systems and combined with customers applications,
image processing systems and there components
for industrial use**

An audit was performed, Report No. **70029415**
Proof has been furnished that the requirements
according to

ISO 14001: 2004

are fulfilled. The certificate is valid until **2010-08-28**
Certificate Registration No. **12 104 16905 TMS**



M. Worgel

Munich, 2007-09-06



EMS-TGA-ZM-07-92

TÜV SÜD Management Service GmbH • Zertifizierstelle • Ridlerstraße 65 • 80339 München • Germany

ISO - certificate

MS01/10.05



EC Declaration of Conformity

QM / page 1 of 1 / FB_7.1-01

Prozess 7.1; 7.2.2; 7.3

Manufacturer: **Pulsotronic-Anlagentechnik GmbH**
Address: **Neue Schichtstraße 7, D-09366 Niederdorf**
Product name: **all catalogue products**

Declaration of conformity

We declare that we are solely responsible for the fact that the outlined products comply with the requirements of the following European directives:

Number: **2004/108/EG**

Text: Directive 2004/108/EU by the European Parliament and the Council on the harmonization of the legal requirements of the member states concerning the electromagnetic compatibility and on the annulment of Directive 89/336/EMS dated 15 December 2004 (Official Journal No. L390 dated 31 December 2004, Page 24)

Number: **2006/95/EG**

Text: Directive 2006/95/EU by the European Parliament and the Council on the harmonization of the legal requirements of the member states concerning electrical materials for use within certain voltage limits dated 12 December 2006 (Official Journal – EU dated 27 December 2006, No. L374, Page 10)

Number: **2006/42/EG**

Text: Directive 2006/42/EU by the European Parliament and the Council concerning machinery and on the modification of directive 95716/EU dated 17 May 2006 (Official Journal No L 157 dated 09 June 2006, Page 24), modified as a result of a correction dated 16 March 2007 (Official Journal - EU dated 16 March 2007, No. L76, Page 35)

Issued by: Pulsotronic-Anlagentechnik GmbH

Place, date: Niederdorf, 01.01.2008

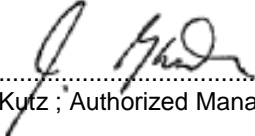
Legal signature: 
Name, title: M. Kutz ; Authorized Manager

This declaration certifies the compliance with the aforementioned directives, but does not include any assurance of properties.

The Safety Information in the supplied product documentation must be observed.



Subject to change without notice!
Rev. 0901

Control units

MESEP / Digital+ / M-Pulse

Overview

Different fields of application require accordingly adapted solutions. Pulsotronic provides the solutions for your application - not only for sensors but also for the corresponding operating electronics. We offer three different electronics:

- MESEP
- Digital+
- M-Pulse

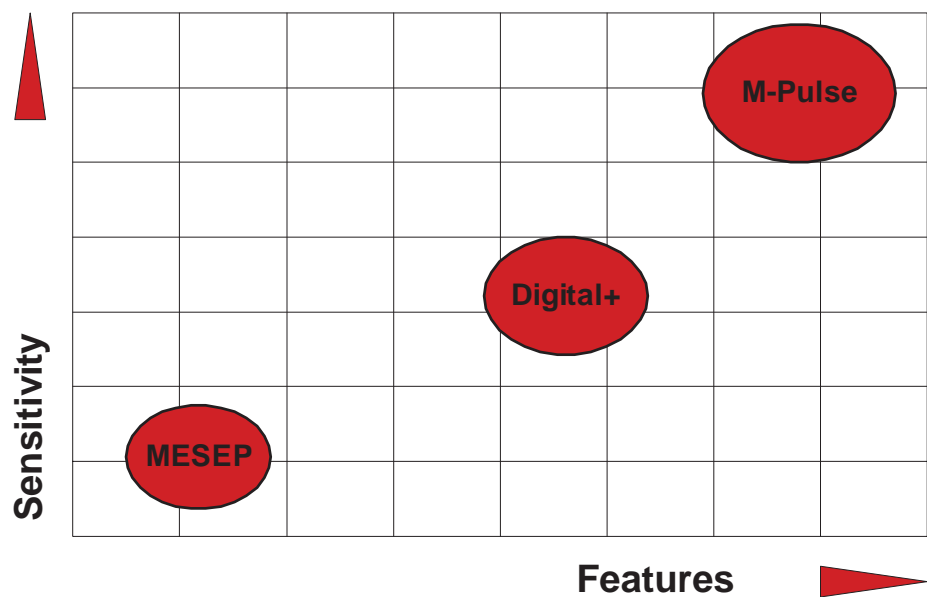

Control unit

The simple MESEP-electronics works completely analog and is characterised by an easy handling. The Digital+ offers digital filters, evaluation and a high-sensitivity operating electronics with self-monitoring. The sensitivity is considerably higher as the MESEP-electronics. Furthermore it is possible to operate much more peripheral units. The display and the keyboard provide for concise and uncomplicated indication. The M-PULSE-electronics stands for highest sensitivity and equipment. Additionally to the functions of the Digital+ the M-PULSE permanently monitors the sensor. A multiprocessor system serves for signal analysis. Similar to the Digital+ the analysis is based on a high-sensitive HDC-IQ receiver (homodyn direct conversion quadrature receiver). Further optional components complete the M-PULSE-electronic perfectly. The connection to Ethernet oder WLAN for example is no problem. Alternative control units, signal transmitter oder printers are available.



Technical data - short overview

Type	MESEP	Digital+	M-Pulse
	Standard	→	High-End
Function			
Signal generation	analog	digital	digital
Signal processing	analog	analog & digital	analog & digital
Signal analysis	analog	digital	digital
Self-monitoring	-	yes	yes
Sensor-monitoring	-	-	yes
Operating frequency	~100 kHz	50 - 650 kHz	50 - 650 kHz
Logging & real-time clock	-	-	yes
Product fade-out	-	yes (3 products)	yes (199 products)
Digital filter	-	yes	yes
Networking	-	-	Ethernet; WLAN; RS232/485
Operating elements	potentiometer	plastic foil keyboard (6 Keys)	plastic foil keyboard (11 Keys)
Display	LED	LED & LC-Display (2x20 characters)	LED & LC-Display (4x20 characters)
Transducer (optional)	-	1x sirene o. flashligh	1x sirene 2x flashligh
Interfaces	-	parallel interface (10 I/O)	parallel interface (34 I/O) 3x serial interface
External operating panels (optional)	-	-	M-Pulse Touchpanel M-Pulse Keypanel
Option to control a fre- quency converter	-	start / stop	start / stop speed
Perfomance validation system	-	-	yes
Password protection	-	yes (fix)	yes (configurable)

Further information is given in the data sheets of the particular operating electronics respectively of the particular devices and sensors. If you need any help choosing the right electronics, the right sensor or device, please feel free to contact our service department.



Subject to change without notice!
Rev. 0901

M-Pulse Control

Recording of data and networking with Ethernet/WLAN

- Centralized device management and control
- Data export for further processing or for amending BDE system
- Link to the BDE or PP system using integrated OPC server

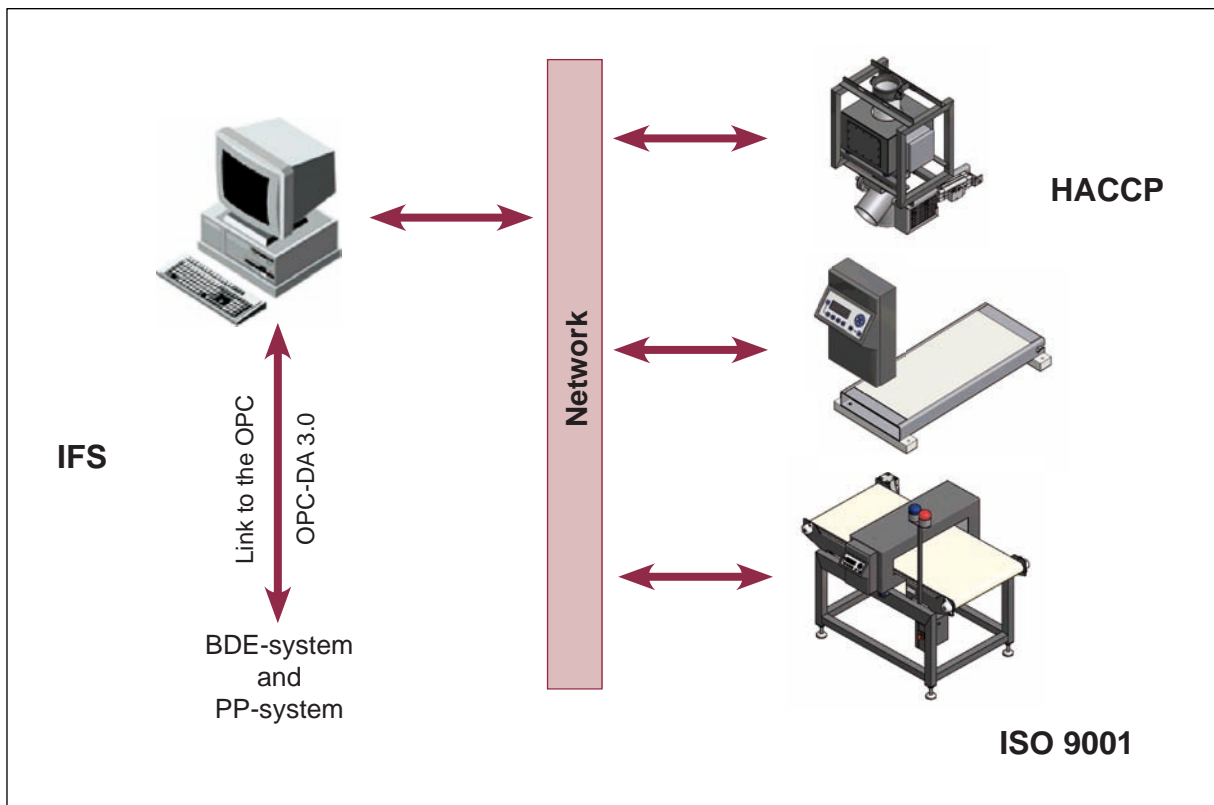

M-Pulse Control

Highlights

- Networking of M-Pulse metal detectors via Ethernet and WLAN
- No restrictions on number of devices
- Easy to integrate in existing networks
- Fast and safe installation using Plug 'n Play
- High degree of data security due to SQL databases
- Preparation of individual reports with extensive filtering functions
- Integrated product-diagnosis tool



The networking concept

The highly capable networking concept for the M-Pulse series of devices makes it possible to establish networks with a practically unlimited number of devices. In addition, even devices from other branches can be controlled centrally by one master computer. Use your existing computer network. Thanks to the communication via the standard TCP/IP protocol, full compatibility with almost all network types is guaranteed. Thus, expensive investments for additional new installations (such as RS485) are therefore not necessary. All the series M-Pulse metal detectors can be networked, irrespective of their models. The optionally available Ethernet or wireless LAN module can be retrofitted on site at anytime. To meet requirements of the highest possible level, all the relevant information can be passed on to data recording, controller or planning systems via the integrated OPC server.

The software

The simple and intuitive user desktop makes getting started troublefree. The good arrangement of all the most important information provides immediate information on the status of all the devices.

The equipment overview in the left field shows clearly the state of all devices. Current attitudes can be read off and changed in the right part.

Name	Loggen
<input checked="" type="checkbox"/> Linie 6 links	Ja
<input checked="" type="checkbox"/> Linie 3 links	Ja
<input checked="" type="checkbox"/> Linie 2 links	Ja
<input checked="" type="checkbox"/> Linie 4 links	Ja
<input checked="" type="checkbox"/> Linie 10 links	Ja
<input checked="" type="checkbox"/> Linie 8 links	Ja
<input checked="" type="checkbox"/> Linie 9 links	Ja
<input checked="" type="checkbox"/> Linie 5 rechts	Ja
<input checked="" type="checkbox"/> Linie 7 rechts	Ja
<input checked="" type="checkbox"/> Pute Linie 1	Ja
<input checked="" type="checkbox"/> Linie 12 links	Ja
<input checked="" type="checkbox"/> Linie 11 links	Ja
<input checked="" type="checkbox"/> Linie 13 links	Ja
<input checked="" type="checkbox"/> Pute Linie 2	Ja
<input checked="" type="checkbox"/> Reserve	Ja

Datum	Uhrzeit	Meldung
22.02.2007	15:35:00	Produktwechsel
22.02.2007	15:34:34	Produktwechsel
22.02.2007	15:31:14	Produktwechsel
22.02.2007	15:31:14	Gerät online
22.02.2007	15:00:10	Gerät offline
22.02.2007	13:27:35	Produktwechsel
22.02.2007	13:27:35	Gerät online
22.02.2007	13:27:09	Gerät offline
22.02.2007	13:12:27	Produktwechsel
22.02.2007	13:11:26	Produktwechsel
22.02.2007	13:06:53	Gerät online
22.02.2007	13:01:01	Benutzerwechsel
22.02.2007	13:00:55	Produktwechsel
22.02.2007	12:02:00	Produktwechsel
22.02.2007	11:27:44	Gerät online
22.02.2007	11:17:19	Gerät offline
22.02.2007	11:16:55	Gerät online

Clearly and temporal arrangedly appears the announcement history to the corresponding device in the right part.



Adapted functionality

Prepare individual reports and evaluations with the help of countless filter functions and setting options.

Prepare completely individual reports for yourself. Ex-tensive filtering functions and the incorporation of header data, such as addresses or company logos, help you with this. The flexibility of M-Pulse Control guarantees that you can also comply with any future requirements in accordance with the standards

p-u-l-s-o-t-r-o-n-i-c

Pulsotronic-Anlagentechnik GmbH
 Neue Schichtstraße 7
 D-09366 Niederdorf

annual report for device demo
 year: 2005

summary
 period of time: 03.11.2005 11:39:45 - 09.12.2005 11:31:41
 metal: 281
 device offline: 3
 device online: 4
 line test: 12
 product change: 13
 lot numbers change: 9
 user change: 8
 cleaning mode: 4
 device error: 0
 false alarm: 0

messages:

03.11.2005 11:39:45 device online
 03.11.2005 11:41:15 metal amount: 0028mV Phase: 326°
 03.11.2005 11:41:18 metal amount: 0025mV Phase: 329°

M-Pulse Control

The export functions provide you with limitless possibilities. If necessary. You can even export prefiltered data and then process and display it using other programs.

metal alarm line 32

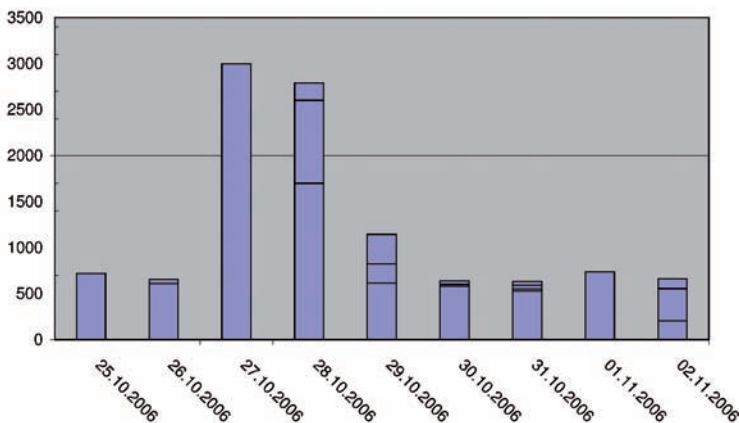

View of the sum of the metal alarms of some days.



The complete program package

Other useful tools are also included to complement M-Pulse Control.

M-Pulse Control

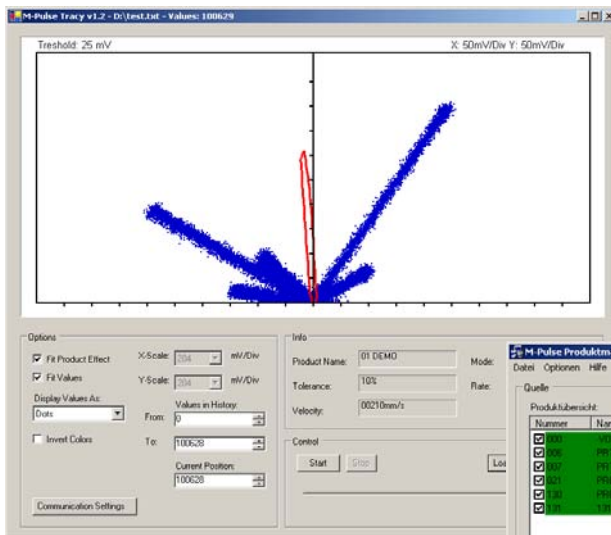

The M-Pulse Tracy software makes it possible to directly display the collected test values. Thus, faults, such as vibration, can be localised much faster.

With the help of the M-Pulse Product Manager, you can manage all the products comfortably on the PC. The complete product data can even be saved on the hard disk and reloaded when needed. This means that there are practically no limits on the product numbers.

Naturally, you can receive a demo version at no charge. As your competent partner, we are also available to you if you have any additional questions!





p-u-l-s-o-t-r-o-n-i-c

Subject to change without notice!
Rev. 0901

Control unit

M-Pulse

Application

The control and evaluation electronics M-PULSE combines highest sensitivity with reliability and an easy handling. Due to the latest electronics in its' inside the M-PULSE provides an efficient fade-out of the product effect and adapting digital filters. 18 switching outputs, 16 switching inputs, 2 analog inputs and several interfaces allow great flexibility for the control of peripheral units or other equipment as well as for processing commands. The entire workflow is logged and saved. Even in case of a voltage drop the maximum 2048 data records will not get lost. Via the network connection all data can be analysed and archived easily on a pc. Thus the M-PULSE especially is appropriate for quality control applications - for example in the food industry.



Control unit M-Pulse

Function

The device constantly checks the correct functioning of the sensor and the electronics. The electronics is able to adjust automatically on each sensor. This allows entirely maintenance-free operation. Drift actions caused by temperature or deterioration are eliminated. Expensive calibration and production downtimes can be avoided. The sensor signals are dressed using modern DDS-technology. A 32-Bit processor system analyses the dressed data in real time and filters out product effects and interferences reliably. The device provides several interfaces. Thus it can be integrated perfectly in automated manufacturing and is able to realise control tasks itself. The device also provides for connection with LAN/WLAN. The entire workflow can be logged and analysed according to HACCP, ISO or IFS.



Equipment & specific characteristics

Intuitional handling

The uncomplicated handling concept is supported by usable features as the displays' reduction on the required information. Depending on the particular adjustments of each user certain menus can be blanked entirely.

Message- and reporting system

The device has an internal memory which is able to collect maximum 2048 messages. Every change of the user, of the charge and each metal alarm are recorded without interruption. Via network the data can be transferred to a pc and there be evaluated. With our software „M-Pulse Control“ the user is able to write and to archive reports according to HACCP or IFS.

Product memory & -fade-out

Different products may require different adjustments on a device - for example concerning the stream velocity. These specific adjustments as well as the data of the product effect are stored in the electronic memory for 199 products. This data can be recalled if necessary with a simple keystroke. As easy as saving and recalling this data also is the breaking-in of the product effect. A demonstrator will accompany you step by step through the whole process - from the input of the name until the data acquisition.

Performance check

If regular tests for the validation (HACCP; IFS; ISO) of the sensor functioning are necessary, the electronics will support that using the integrated testing system. The tests will be requested from the user in optional intervals. Supported by a demonstrator the user operates the test successively. The device itself does not require such tests as it works maintenance-free. Additionally it constantly is controlled by internal self tests.

Modern electronics

Developping the electronics we attached great importance to savety and reliability. All important function blocks are equipped with self diagnostics systems. If errors occur, they will be identified, logged and displayed. The sensor is supplied via a high-power amplifier. All signals are generated by modern DDS signal transducers which work crystal stable and without drift. The modern HDS-IQ-receiver detects even smallest signals. A 32 bit multiprocessor system allows a fast and efficient evaluation of the signals. For the connection of the system to the environment there are several serial and parallel interfaces are available.



Technical data

Control unit M-Pulse

Mechanical data	
Dimensions	W x H x D: 200 x 300 x 80 mm
Weight	4 kg
Handling	
Keyboard	11 keys (4x arrow; ESC; enter; password; 4x function key)
Display	4 x 20 characters; illuminated (blue); brightness & contrast adjustable
Conditions of use	
Storage temperature	-10°C .. 60°C
Operating temperature	0°C .. 50°C
Protection class	IP 65
Supply voltage	85 - 264 VAC; 50/60 Hz
Power consumption	typ. 20 W; max. 100 W
Electrical connection	3 m cable; L1,N,PE; 1,5 mm ²
Sensitivity	
	(see sensor or device)
Interfaces	
Sensor - transmitter	50 Ohm; overload- & short-circuit proof (50 .. 650 kHz)
Sensor - receiver	HDC-IQ - receiver with sensor-readjustment and monitoring
Digital inputs	16 Stk.; optical isolated; $V_{IL} = -5 .. 1,5V$; $V_{IH} = 6 .. 50V$ multifunction-key external product selection ejection and level guard light barrier for synchronize the ejector transifunction; external stop; external failure
Analog inputs	2 pieces; 0 .. 10V; resolution 10bit (one for external speed gathering)
Digital Outputs (low power)	12 pieces; high-side/open-drain; max. 20 mA; overload- & short circuit proof device state outputs to control a frequency converter
Digitale outputs (high power)	6 pieces; high-side/open-drain; max. 200 mA; overload- & short circuit proof 3x transducer ejector device is in stopped state
Interface - printer	RS232 & power supply for M-Pulse printer
Interface - touchpanel	interface & power supply for M-Pulse touchpanel
Interface - networking	optional RS232; RS485; ethernet or WiFi
Relay	2x change-over contact; 48 V, 5 A; function eligible
Voltage output	24VDC; stabiliszed, overload- & short circuit proof; max. 25W for external components



Order information & accessories

Designation	Order number
M-Pulse control unit with wall holder	16730000021
M-Pulse control unit	16730000020
M-Pulse printer IP 65	08410000114
M-Pulse printer IP 20	08410000113
M-Pulse connecting kit ethernet (non pluggable)	08410000108
M-Pulse connecting kit ethernet (pluggable)	with 5 m cable: 08410000107 with 10 m cable: 08410000124 with 15 m cable: 08410000125
M-Pulse connecting kit WiFi	08410000109
M-Pulse connecting kit RS485 (pluggable)	08410000101
recommended RS485-PCI-card for PC	08410000009
M-Pulse connecting kit RS232	08410000104
M-Pulse touchpanel	08410000110
M-Pulse touchpanel with wall holder	08410000111
Software M-Pulse Control & Tools	08410000106

Beyond the components listed above many other optional components are available depending on the type of device. Exact information is given in the particular data sheets.

Software M-Pulse Control

The software M-PULSE Control serves for a complete documentation of the production process. By the software all detectors can be linked via RS485, Ethernet or WLAN. The software permanently collects all relevant parameters and archives them in the data base. The data can be recalled, analysed or exported as requested. The program contains further tools for processing and diagnostics. Thus product adjustments can be edited and archived on the pc and the measured value acquisition can be pursuit live. If you are interested please ask for a gratis demo version of the software.

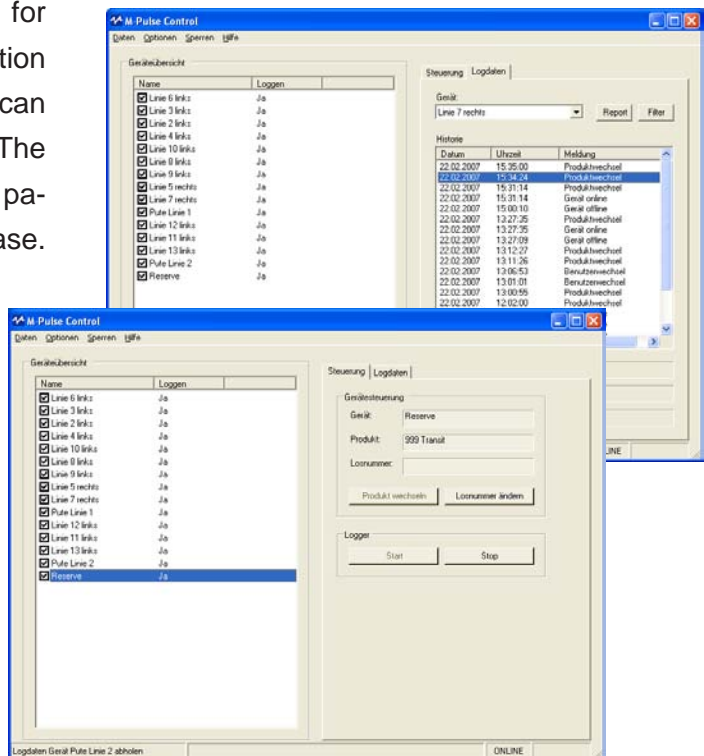



p-u-l-s-o-t-r-o-n-i-c

Subject to change without notice!
Rev. 0901

Control Unit

Digital+

Application

The Digital+ electronics is the enhancement of our approved digital electronics. New equipment as digital filters, the possibility to fade out the product effect, the memory capacity for three products and an improved display provide for a superior sensitivity. The electronics is used where high sensitivity, reliability and operator convenience are required - in the plastics as well as in the recycling industry.



Control unit Digital+

Function

The device constantly controls the correct functioning of the electronics. The adjustment to the connected sensor is done fully automatically. This allows maintenance-free operation. Drift actions caused by thermal fluctuation or deterioration are eliminated. Expensive calibration and production downtimes can be avoided. The sensor signals are dressed using modern DDS-technology. A 32-Bit processor system analyses the dressed data in real time and filters out product effects and interferences reliably. The device can be controlled via several in- and outputs. Piloting and supply of signal transmitters, sensors and plants are directly effected via the control system. The Digital+ electronics enables the user to operate conveyor plants etc. with our BD- or TU-sensors.



Equipment and specific characteristics

Easy handling

The device is operated easily. Generally the user only varies the sensitivity and teaches-in the parameters for the product effect. There are no complex menus. Further modulations are possible via an access code. Thus the function of filters and peripheral units can be adjusted. All values are already preset. Normally changes are not necessary.

Product memory & product fade-out

If the test material has a product effect, this can be faded out by the electronics. The effect is taught-in and saved with pushing a button. There is a memory capacity for three products. Each memory space can be addressed fast via a button. Three LEDs signalise if there is a product loaded and which product it is. New products are taught-in fully automatically by pushing a button. Complex adjustments are redundant.

Operation & maintenance

The device is entirely maintenance-free. An integrated self-diagnosis function immediately signalises malfunctions. All components are placed on a modern multilayer circuit board. The connections are completely pluggable. By this it is possible to change the circuit board in only a few minutes on-site. Due to modern technology and the latest semiconductor technology the energy consumption is at only 10W. This reduces costs and protects

the environment.

Designs

According to the application the customer chooses among two different housings. For normal environmental conditions the powdered metal housing in protection class IP 54 is appropriate. For applications with rough environmental conditions a stainless steel housing with protection class IP 65 is available.

Control system

The electronics is equipped with several in- and outputs. Thus the external peripheral units can be piloted and important signals can be collected via the sensor. The device can be integrated in conveyor lines or separators without the need of modifications.



Technical data

Mechanical data	
Dimensions IP54	B x H x T: 200 x 200 x 80 mm
Dimensions IP65	B x H x T: 200 x 300 x 80 mm
Weigth	3 kg
Handling	
Keyboard	6 Keys (2x arrow; enter; 3x Keys for products)
Display	2 x 20 characters; illuminated (blue)
Conditions of use	
Storage temperature	-10°C .. 60°C
Operating temperature	0°C .. 50°C
Protection class	IP 65 / IP 54
Supply voltage	85 - 264 VAC; 50/60Hz
Power consumption	typ. 10W; max. 40W
Electrical connection	3m connecting cable; L1,N,PE; 1,5 mm ²
Sensitivity	
	(see sensor or device)
Interfaces	
Sensor - transmitter	50 Ohm; overload- & short-circuit proof (50 .. 650 kHz)
Sensor - receiver	HDC-IQ - receiver with sensor-readjustment
Digitale inputs	4 piece; optical isolated; $V_{IL} = -5 .. 1,5V$; $V_{IH} = 6 .. 50V$ multifunction-key ejector-guard
Digitale outputs	6 piece; high-side/open-drain; max. 200mA; overload- & short-circuit proof transducer ejector device state
Serial interface	2x (mode of operation on request)
Relay	2x change-over contact; 250V, 1A; function eligible
Voltage output	24VDC; stabilized, overload- & short-circuit proof; max. 2,5W for external components
Ordering information	
Digital+ control unit ferros housing IP 54	16730000025
Digital+ control unit stainless steel IP 65	16730000024



Dimensions

Control unit Digital+

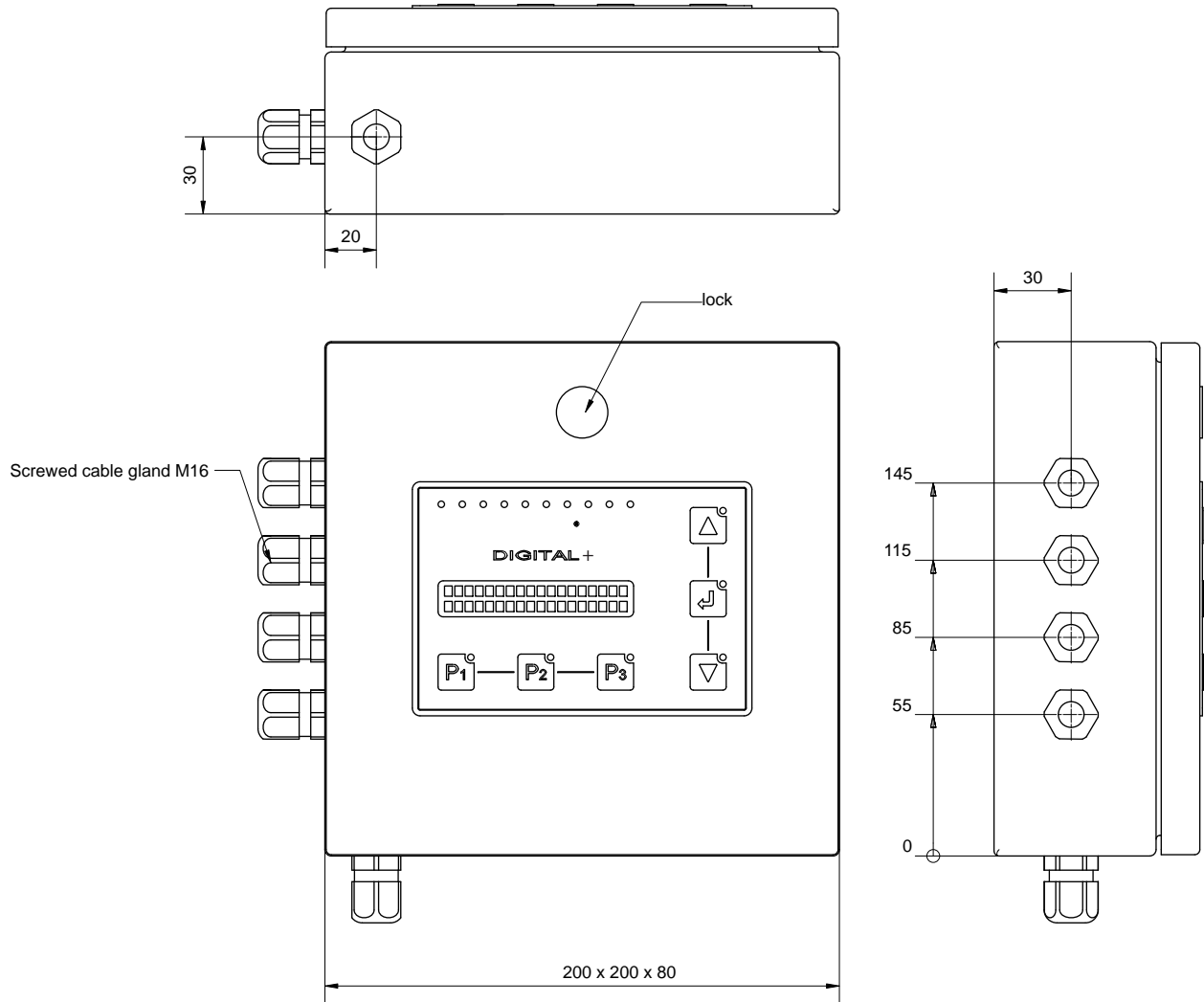

Digital+ control unit
ferros housing IP54

order number 1673000025



p-u-l-s-o-t-r-o-n-i-c

Subject to change without notice!
Rev. 0901

Control unit

MESEP®

Application

The easy-handling MESEP electronics functions completely analog. The sensitivity can be adjusted via a rotary potentiometer. This electronics is an integral part of a ring sensor and is situated directly on the device/sensor.

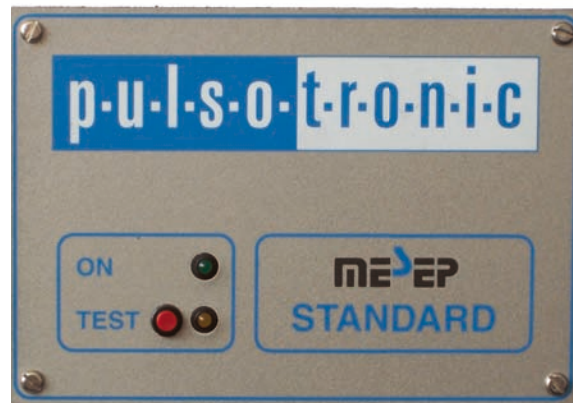

Control unit MESEP

Function

An oscillator in the ring sensor excites a high-frequency, electromagnetic alternating field. Metal entering in the sensor causes eddy currents that withdraw energy from the field. This loss of energy causes a damping of the oscillator by which the amplitude of the signal is lowered. The damping degree is a measure for the dimension of the metallic object. The evaluation unit detects the damping of the oscillator. If the value of the damping falls below a defined threshold, the switching amplifier is activated and excites an output signal.



Technical data

Mechanical data	
	The electronics is integrated in the device.
Handling	
Adjustment of sensitivity	potentiometer (lockable)
Push-button	functional test
Display	1x stand-by signal
Application conditions	
Storage temperature	-10°C .. 60°C
Operating temperature	0°C .. 50°C
Protection class	(see sensor or device)
Supply voltage	230 VAC / 50 Hz oer 115 VAC / 60 Hz
Power input	typ. 35 W; max. 40 W
Electric connection	3 m connecting cable; L1,N,PE; 1,5 mm ²
Sensitivities	(see sensor or device)
Interfaces	
Sensor	LC-Oscillator with straigth receiver
Digital inputs	Button for functional test
Digital outputs	2 outputs.; open collector; max. 24 VDC; 100 mA signal transducer ejection
Switching relays	1 piece; 250 V; 5 A Metal alarm



Subject to change without notice!
Rev. 0902

Flat sensor MESEP®

AR

Application

These flat sensors are detectors for all types of metal for the use in conveyor belts and chutes. Using them it is possible to inspect bulk material as well as finished goods. Foils or other roll goods can be led directly over the sensor and thus be detected on metallic contamination. The sensors serve for quality assurance as well as for machine protection. Beyond that the flat detectors are also appropriate for applications of the process control e.g. for object counting or for completeness checks. The flexible system of three different sensors allows variations in width. Starting from 95 mm there is no limit upwards. Moreover the sensors can be mounted above and below the conveyor belt (sandwich combination) in order to increase the sensitivity. In combination with the optionally available control unit conveyor plants and discharging units can be controlled directly.

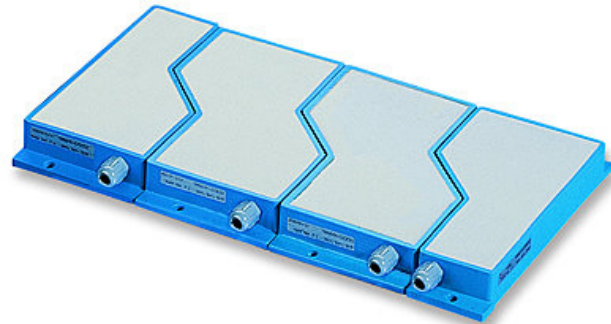

Flat sensor MESEP® AR

Function & handling

The sensor has a dynamic working principle which means it only detects moving metallic pieces in the sensor range. If a non-moving metal piece is situated in the detection range, it does not excite a signal and therefore is not detected. Contrary to sensors with a static working principle this system allows operation with a much higher sensitivity. Thus even small metallic pieces can be detected dead reliable. The operation of the sensor requires a control unit. This realises the voltage supply for the sensors and allows the adjustment of all parameters. The detailed functioning and handling depends on the control unit.

Specific characteristics

- sensors endlessly alignable (>95 mm)
- no metal-free zones necessary
- stable and shook-proofed aluminium housing
- easy mounting
- separate control electronics with freely adjustable functions
- protection class IP67
- sensitivity adjustable via control electronics



Rules for combining sensors

In order to avoid dysfunctions caused by the combination of several sensors please pay attention to the following facts:

1. Between sensors belonging to the same family of frequencies it is necessary to respect a minimum distance of 300 mm (see illustration 1).
2. Flat sensors with different designs can be aligned without paying attention to the frequency (see illustration 2).
3. For sandwich combination it is necessary to respect a minimum distance of 40 mm between the upper and the lower sensors.

Rules for sandwich combination

For assembling flat sensors as a sandwich there are different possibilities:

1. Sensors with the same housing design are placed on top of each other in the same position (see illustration 3).¹
2. In one layer there are only broad sensors, in the other one only small sensors (see illustration 4).²

Combination examples

belt width [mm]	necessary flat sensors
95	95R
140	140
150 - 160 ³	95L-95R
195 - 200 ³	95L-140
240	240
250 - 260 ³	95L-140-95R
295 - 300 ³	95L-240
340	140-240
350 - 360 ³	95L-240-95R
395 - 400 ³	95L-140-240
440	240-240
450 - 460 ³	95L-140-240-95R
495 - 500 ³	95L-240-240
540	140-240-240
550 - 560 ³	95L-240-240-95R
595 - 600 ³	95L-140-240-240
640	240-240-240
650 - 660 ³	95L-140-240-240-90R
695 - 700 ³	95L-240-240-240
740	140-240-240-240
750 - 760 ³	95L-240-240-240-95R
795 - 800 ³	95L-140-240-240-240
840	240-240-240-240
850 - 860 ³	95L-140-240-240-240-95R
895 - 900 ³	95L-240-240-240-240
940	140-240-240-240-240
950 - 960 ³	95L-240-240-240-240-95R
995 - 1000 ³	95L-140-240-240-240-240
1.040	240-240-240-240-240

¹ Repeating a module number in such a construction is not allowed. Thus the maximum width is limited on 750 mm. 95'er modules in a sandwich basically should have different frequency numbers.

² In this case there is no limit set to the combination. But it is necessary to keep a distance of at least 600 mm between identical sensors. The modules 1F1 to 1F4 are applicable as in illustration 1.

³ Between a 95'er module and its' neighbour element it is possible to keep a crack of 5 mm which does have no influence on the sensitivity. By this the entire width can be varied accordingly.



p-u-l-s-o-t-r-o-n-i-c

Flat sensor MESEP® AR

Type	MESEP® AR 95R	MESEP® AR 95L	MESEP® AR 140	MESEP® AR 240
Mechanical data				
Dimensions	L x W x H: 205 x Width x 30 mm			
Housing	Aluminium; blue; powder-coated (active surface polyurethane)			
Weight	800 g		1.250 g	2.500 g
Electrical data				
Supply voltage	15 VDC			
Output	Analog voltage output			
Electrical connection	PVC - cable; 2 m or 5 m			
Conditions of use				
Storage temperature	-10°C .. 50°C			
Operating temperature	-10°C .. 50°C			
Protection class	IP65			
Speed	1 - 120 m/min			
Sensitivity	(Maximum distance between the sensor and the test piece)			
Fe-plate 30 x 30 x 1mm	75 mm			
Fe-plate 12 x 12 x 1mm	55 mm			
Nut M6	45 mm			
Fe-ball Ø 7,0mm	35 mm			
Nut M4	35 mm			
Washer M4	29 mm			
Nut M2,5	26 mm			
Fe-ball Ø 4,5mm	24 mm			
Fe-ball Ø 3,0mm	15 mm			
Fe-ball Ø 2,5mm	10 mm			
Fe-ball Ø 2,0mm	5 mm			
Order information	(All order numbers for sensors with 2 m cable; 5 m on request)			
Frequency group 1	08317690900	-	08317691000	08317691100
Frequency group 2	08317690930	-	08317691030	08317691130
Frequency group 3	-	08317690931	08317691031	08317691131
Frequency group 4	-	08317690932	08317691032	08317691132
Control unit	Standard		for top hat rail	with reverting contactor
	08349005000		08349005001	08349005002



p-u-l-s-o-t-r-o-n-i-c

Dimensions

Flat sensor MESEP® AR

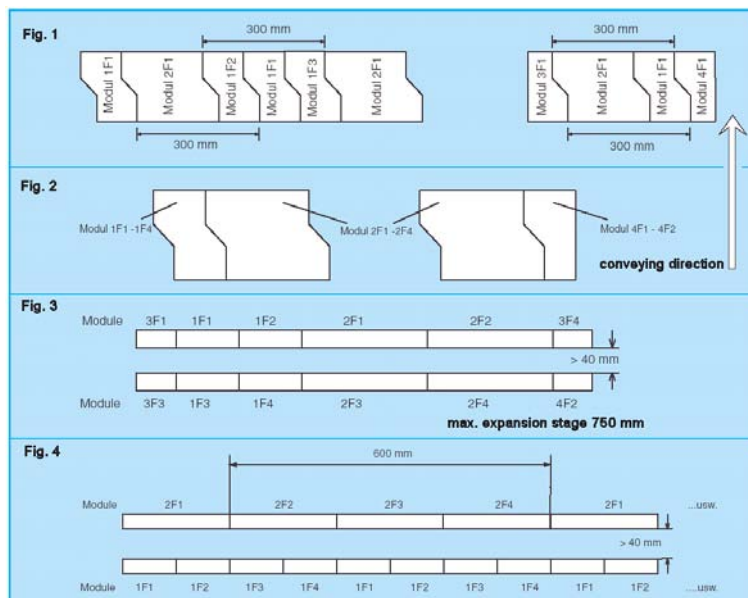
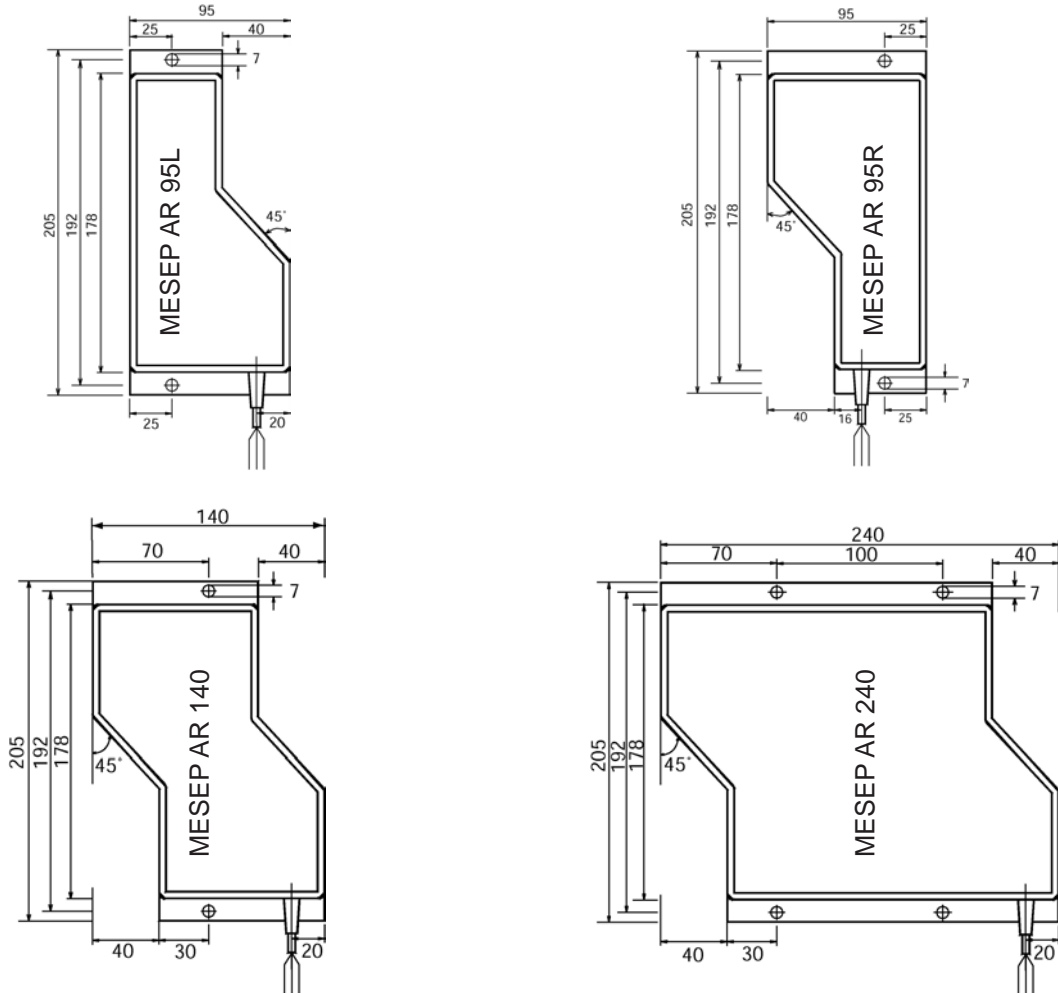



Subject to change without notice!
Rev. 1101

Flat sensor with spatial resolution MESEP®

FS

Application

These high-sensitivity flat sensors stand out for their localized resolution of smallest metallic pieces. This implies that metallic residua is not only detected but also localized in the sensor. Thus this detector type particularly is appropriate for the use in the recycling industry. It enables the user to separate metallic contamination precisely accurate from the material stream. Granulate or hackled material can be sorted easily. The sensor can be used in conveyor belts, slides or in free-fall applications.

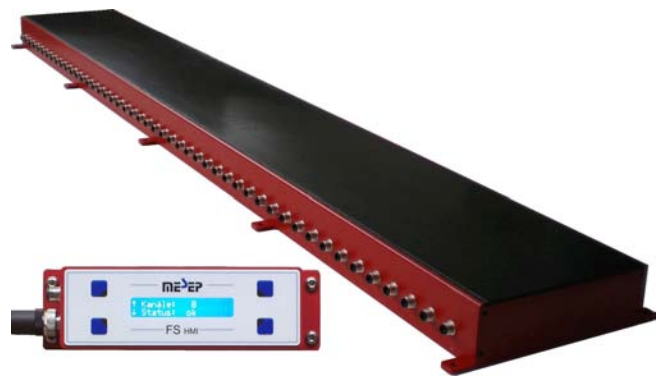

MESEP® FS

Function

The sensor has a dynamic working principle which means it only detects moving metallic pieces in the sensor range. If a non-moving metal piece is situated in the detection range, it does not excite a signal and therefore is not detected. Contrary to sensors with a static working principle this system allows operation with a much higher sensitivity. The sensor provides several channels which are arranged parallelly. Each of them is equipped with an own sensor coil and evaluation unit. By this the position of the metallic object can also be detected. Operation is realised via a separate control element or via pc. The control system can also be realised using a PLC.

Specific characteristics

- different sensor widths available (80 mm - 2,000 mm)
- various resolutions (20 mm - 100 mm)
- sensor with max. 100 channels
- ejectors or flaps internally controlled
- no metal-free zones necessary
- stable and torsion-free aluminium housing
- easy mounting
- separate control element available
- interface for PC or PLC
- protection class IP65
- sensitivity adjustable via control electronics

Type	MESEP® FS
Mechanical data	
Dimensions	L x W x H: Length x 210 x 60,5 mm
Number of channels	4 .. 100 pieces
Resolution (Width of each channel)	20 .. 120 mm
Length	(Number of channels + 1) x Resolution (max. 2,000 mm)
Housing	Aluminium - strand profil
Active surface	POM
Electrical data	
Supply voltage	20 .. 25 VDC
Power consumption	10 mA for each channel
Output	switching output for each channel; NPN / normally open ; 24 VDC; 50 mA
Interface	RS232 (for PC or PLC)
Connector ¹	switching output: Female connector M12; 4pins Power supply: Female connector with plug Control unit: Female connector M12; 4pins Interface: Female connector M12; 4pins
Conditions of use	
Storage temperature	-10°C .. 70°C
Operating temperature	-10°C .. 60°C
Protection class	IP65
Speed	5 .. 300 m/min (0,1 .. 5 m/s)

Ordering code:

Type	Resolution [mm]	Number of channels	
MESEP® FS	35	-	12 (z.B.: MESEP® FS 35-12)

When selecting the resolution and the number of channels please do not exceed the maximum sensor length of 2 m.

¹ Devices with cable or other jacks at request.



Sensitivity

Type	FS 20 - 49	FS 50 - 120
Test piece		
Ferrous-ball Ø 4,5 mm	24 mm	30 mm
Ferrous-ball Ø 3,0 mm	15 mm	20 mm
Ferrous-ball Ø 2,5 mm	11 mm	14 mm
Ferrous-ball Ø 2,0 mm	7 mm	8 mm

The data refers to the clear distance between test object and the upper edge of the sensor. The values are valid for the entire temperature range and for speeds from 5 to 200m/min.

MESEP® FS

Accessories

Designation	Article number
Control unit with cable	MESEP® FS HMI
Connecting cable for PC & Software for Windows 2000 or XP	When ordering please specify
Connecting cable 2 m for connection to M12	44505125310
Connecting cable 5 m for connection to M12	44505125312
Connecting cable 2 m for connection to M12 (righth-angle plug)	44505123910
Connecting cable 5 m for connection to M12 (righth-angle plug)	44505123912

Dimensions MESEP® FS

MESEP® FS

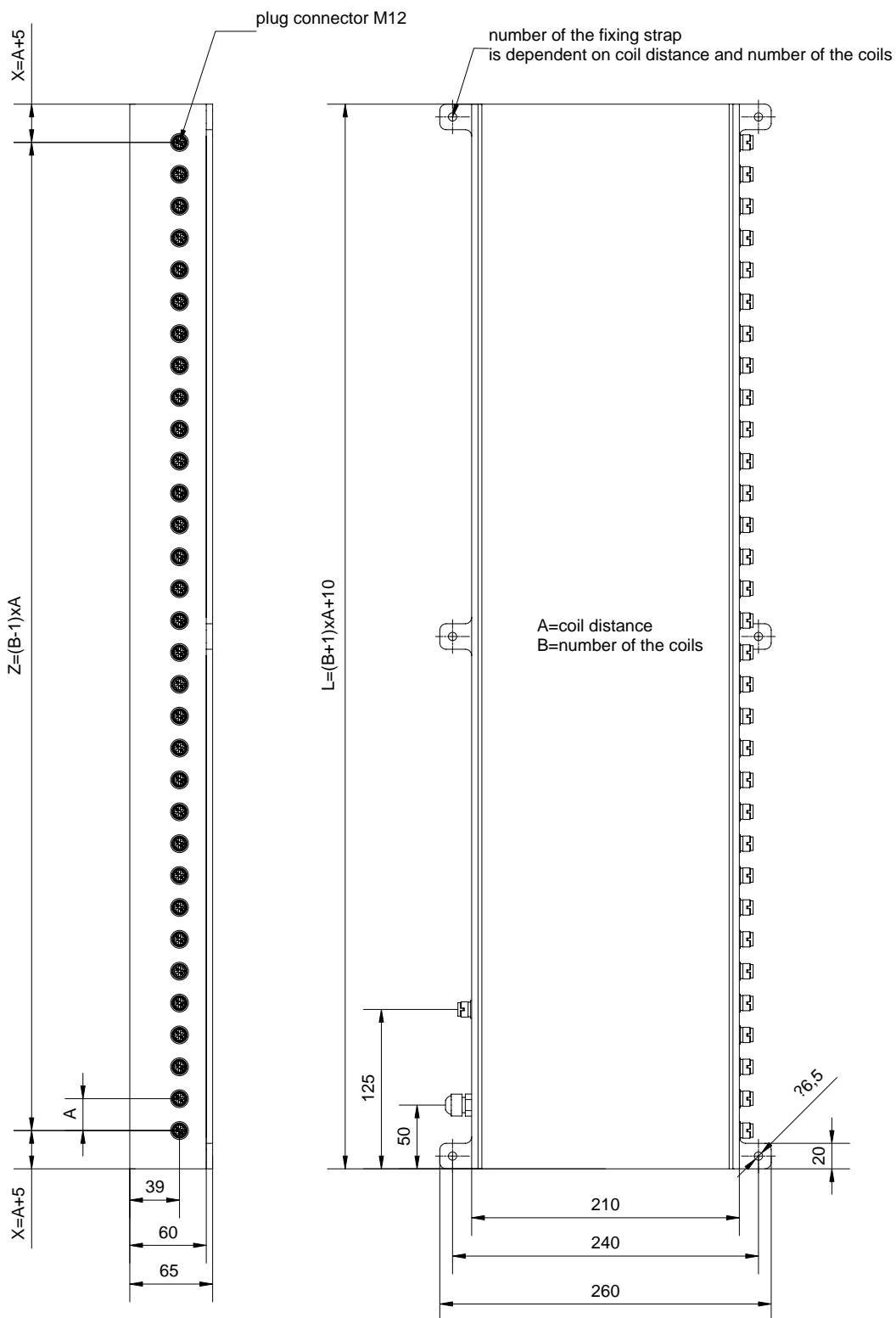



Subject to change without notice!
Rev. 0902

Flat sensor MESEP®

SP

Application

These flat sensors are detectors for all types of metal for the use in conveyor belts and chutes. Using them it is possible to inspect bulk material as well as finished goods. Foils or other roll goods can be led directly over the sensor and thus be detected on metallic contamination. The sensors serve for quality assurance as well as for machine protection. Beyond that the flat detectors are also appropriate for applications of the process control e.g. for object counting or for completeness checks. In combination with the optionally available control unit conveyor plants and discharging units can be controlled directly.



Flat sensor MESEP® SP

Function & handling

The sensor has a dynamic working principle which means it only detects moving metallic pieces in the sensor range. If a non-moving metal piece is situated in the detection range, it does not excite a signal and therefore is not detected. Contrary to sensors with a static working principle this system allows operation with a much higher sensitivity. Thus even small metallic pieces can be detected dead reliable. The operation of the sensor requires a control unit. This realises the voltage supply for the sensors and allows the adjustment of all parameters. The detailed functioning and handling depends on the control unit.

Specific characteristics

- different sensor widths available (150 mm - 1200 mm)
- no metal-free zones necessary
- stable and shock proofed aluminium housing
- easy mounting
- separate control electronics with freely adjustable functions
- protection class IP67
- sensitivity adjustable via control electronics



Flat sensor MESEP® SP

Type	MESEP® SP 150 - 1200		
Mechanical data			
Dimension	L x W x H: Length x 210 x 60,5 mm		
Length	150 mm - 1.200 mm (available in steps of 50 mm) ²		
Housing	aluminium - strand profil		
Active surface	polyurethane		
Electrical data			
Supply voltage	15 VDC		
Output	analog voltage output		
Electrical connection	PVC - cable; 2 m		
Conditions of use			
Storage temperature	-10°C .. 50°C		
Operating temperature	0°C .. 50°C		
Protection class	IP65		
Speed ¹	1 - 120 m/min		
Order information			
	Order number	Length ²	
MESEP® SP 150	08317696900	150 mm	
MESEP® SP 200	08317697124	200 mm	
MESEP® SP 250	08317697240	250 mm	
MESEP® SP 300	08317697341	300 mm	
MESEP® SP 350	08410697442	350 mm	
MESEP® SP 400	08317697601	400 mm	
MESEP® SP 450	08317697702	450 mm	
MESEP® SP 500	08317697803	500 mm	
MESEP® SP 550	08317697912	550 mm	
MESEP® SP 600	08410698020	600 mm	
MESEP® SP 650	08317698114	650 mm	
MESEP® SP 700	08317698164	700 mm	
MESEP® SP 750	08410698264	750 mm	
MESEP® SP 800	08317698296	800 mm	
MESEP® SP 850	08317698348	850 mm	
MESEP® SP xxx	on request	> 850 mm	
Control unit (10 fold)	standard	for top hat rail	with reverting conductor
	08349005000	08349005001	08349005002
Control unit (1 fold)	230VAC/24VDC → 08349005010		115VAC/24VDC → 08349005012



Type	MESEP® SP 150 - 1200
Sensitivity	
	Maximum distance between sensor and test piece.
Fe-plate 30 x 30 x 1 mm	95 mm
Fe-plate 12 x 12 x 1 mm	68 mm
Nut M6	56 mm
Fe-ball Ø 7,0 mm	44 mm
Nut M4	44 mm
Washer M4	37 mm
Washer M3	33 mm
Nut M2,5	33 mm
Fe-ball Ø 4,5 mm	30 mm
Fe-ball Ø 3,0 mm	20 mm
Fe-ball Ø 2,5 mm	14 mm
Fe-ball Ø 2,0 mm	8 mm

Instructions for operation with control unit

Depending on the size of the sensor it has a certain number of analog outputs. Each output has to be operated using a control unit. Additionally it is possible to use several single control units or one multi control unit.

Sensor width [mm]	Analog outputs
150 - 250	2
251 - 450	3
451 - 650	4
651 - 800	5
801 - 901	6
901 - 1000	7
1001 - 1200	8

¹ Higher stream velocities can allow the sensitivity.

² Other lengths and in-between sizes on request.



Dimensions MESEP® SP 150 - 399

Flat sensor MESEP® SP

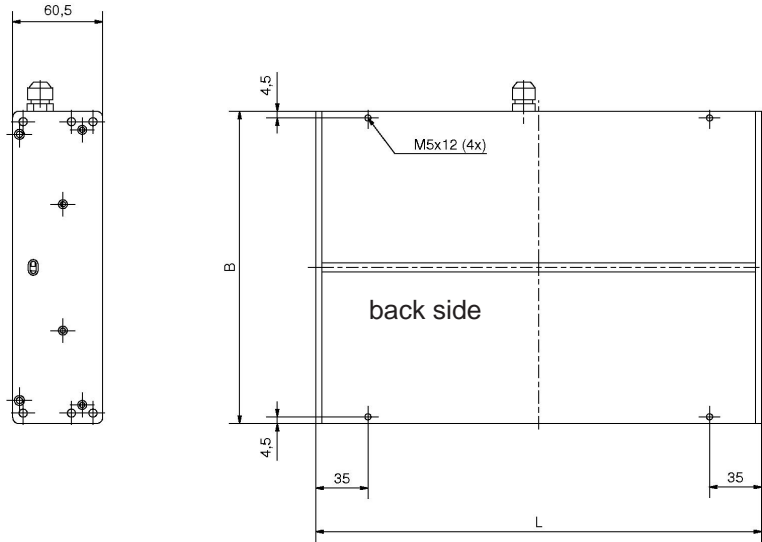

Dimensions MESEP® SP 400 - SP 1200

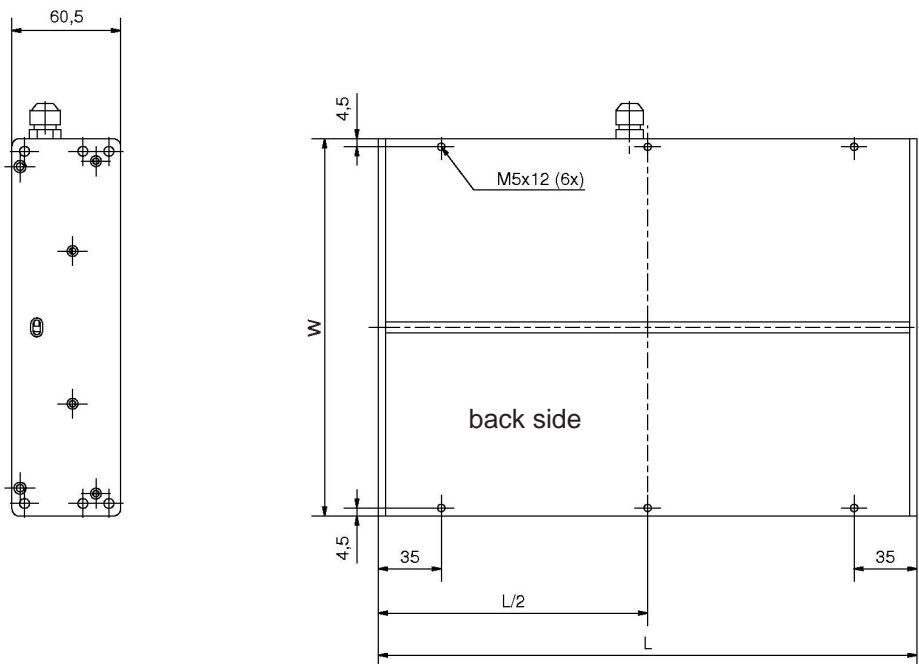



Subject to change without notice!
Rev. 0902

Flat sensor MESEP®

RE

Application

These flat sensors are detectors for all types of metal for the use in conveyor belts and chutes. Foils or other roll goods can be detected on metallic contamination. Thus the sensors serve for quality assurance as well as for machine protection. Beyond that the flat detectors are also appropriate for applications of the process control e.g. for object counting or for completeness check.

Function & handling

The sensor has a dynamic working principle which means it only detects moving metallic pieces in the sensor range. If a non-moving metal piece is situated in the detection range, it does not excite a signal and therefore is not detected. The operation of the sensor requires a control unit. This realises the voltage supply for the sensors and allows the adjustment of all parameters. The detailed functioning and handling depends on the control unit.

Arrangement with several sensors

Each sensor of the RE series is available with two different frequencies. Thus it is possible to eliminate interferences between two close-by sensor. Several sensors can be arranged directly on top of or next to each other. Sensors with different frequencies can be arranged next to each other with no need for a lateral distance. If the sensors are arranged on top of



Flat sensor MESEP® RE

each other it is compulsory to keep a distance of minimum 20 mm! Between sensors with the same frequency a minimum distance of 1 m has to be kept!

Specific characteristics

- compact dimensions - installation height 40 mm
- no metal-free areas necessary
- stable stainless steel housing
- easy mounting
- separate control electronics with freely adjustable functions
- protection class IP65
- sensitivity adjustable via control electronics



Type	MESEP® RE 100		
Mechanical data			
Dimensions	L x B x H: 100 x 130 x 40 mm		
Housing	stainless steel		
Active surface	polyurethane		
Electrical data			
Supply voltage	15 VDC		
Output	analog voltage output (typ. 7,5 V; max. 15 V)		
Electrical connection	PVC - cable; 2 m		
Conditions of use			
Storage temperature	-10°C .. 50°C		
Operating temperature	0°C .. 50°C		
Protection class	IP65		
Speed ¹	1 - 120 m/min		
Order information			
Frequency group 1	08317690011		
Frequency group 2	08317690012		
Control unit (10 fold)	standard	for top hat rail	with reverting contactor
	08349005000	08349005001	08349005002
Control unit (1 fold)	230 VAC / 24 VDC → 08349005010	115 VAC / 24 VDC → 08349005012	
Sensitivity			
Maximum distance between the sensor and the test piece.			
Fe-plate 220 x 330 mm	150 mm		
Fe-plate 30 x 30 mm	70 mm		
Fe-plate 12 x 12 mm	50 mm		
Nut M6	40 mm		
Washer M4	24 mm		
Fe-ball Ø 4,0 mm	18 mm		
Fe-ball Ø 3,5 mm	15 mm		
Fe-ball Ø 3,0 mm	12 mm		
Fe-ball Ø 2,0 mm	6 mm		



Mounting instructions

The sensors can be mounted shielded in metal.

That means:

Metal can approximate the housing sideways and from below. But metal must not protrude on the sensor face! Shielded mounting does not have influence on the detection performance.

Dimensions MESEP® RE 100

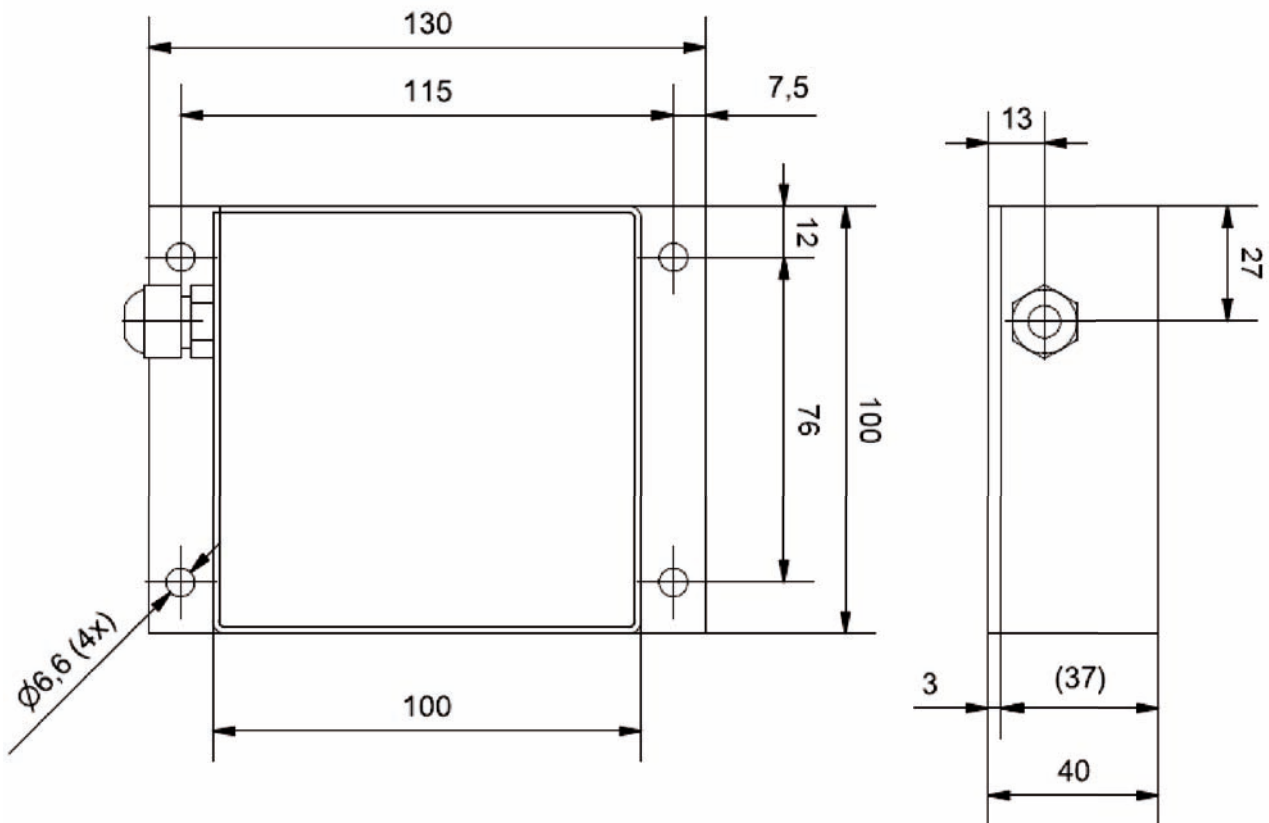

Flat sensor MESEP® RE



Notes

Flat sensor MESEP® RE

3.16

Pulsotronic-Anlagentechnik
GmbH

Neue Schichtstraße 7
D-09366 Niederdorf

Tel.: +49 37296 9383-500
Fax: +49 37296 9383-501

info@pulsotronic-anlagentechnik.de
www.pulsotronic-anlagentechnik.de



Subject to change without notice!
Rev. 0901

Flat sensor M-Pulse / Digital+

FL

Application

Flat sensors are proper for applications where the test material is transported planely on a conveyor belt or a chute. Products like fabric or foil can also be checked on metal without problems. Unlike other flat sensors the FL's working principle is based on a balanced coil system which provides for highest sensitivities. In combination with our high-capacity operating electronics it is possible to fade out product effects and other interferences. The robust, long-living stainless steel housing can be mounted easily.

Function

The working principle of the FL allows a precise analysis of the signals. It is possible to draw conclusions on the signals' origin. Signals can be distinguished into vibration, product or metal. This additional data allows a more sensible reaction on metallic residua. The sensors do not need calibration or maintenance.

Handling

Depending on the operating electronics the handling is realised via a membrane keyboard and a LC-display. Thus all important parameters can be viewed easily and fast and changed if necessary. The sensitivity of the detector also is adjustable this way. Detailed information you will find in the documentation of the electronics M-Pulse and Digital+.



Flat sensor FL

Mounting

The sensing range of the sensor partially is situated above and under the opening of the detector. Big metal pieces can already be detected in this sector. In order to guarantee the accurate functioning of the sensor, these sectors must be kept free of metal. This so-called metal-free zones are divided into two types:

- Metal-free zones for movable pieces
- Metal-free zones for non movable pieces

The dimension of these zones are specified in the particular data sheets.



Type	FL 300 .. FL 2500		
Mechanical data			
Active sensor width X	300 .. 2500 mm (100 mm steps)		
Material	stainless steel (sensor surface epoxy)		
Metal free zone for static parts	300 mm		
Metal free zone for moving parts ²	500 mm		
Conditions of use			
Storage temperature	-10 .. 50°C		
Operating temperature	0 .. 50°C		
Protection class	IP54		
Electrical connection	Supply via control unit (Attached with 3 m cable).		
Sensitivity¹			
Detection width [mm]	ferrous-ball	stainless steel - ball	used sensor
400 mm	1,1	2,2	M-Pulse FL 400
500 mm	1,2	2,2	M-Pulse FL 500
600 mm	1,3	2,3	M-Pulse FL 600
1200 mm	1,5	2,5	M-Pulse FL 1200

Ordering code:

Elektronic	Type of sensor	Dimension [mm]	Example
M-Pulse	FL	Sensorwidth X	M-Pulse FL 1400
Digital+			

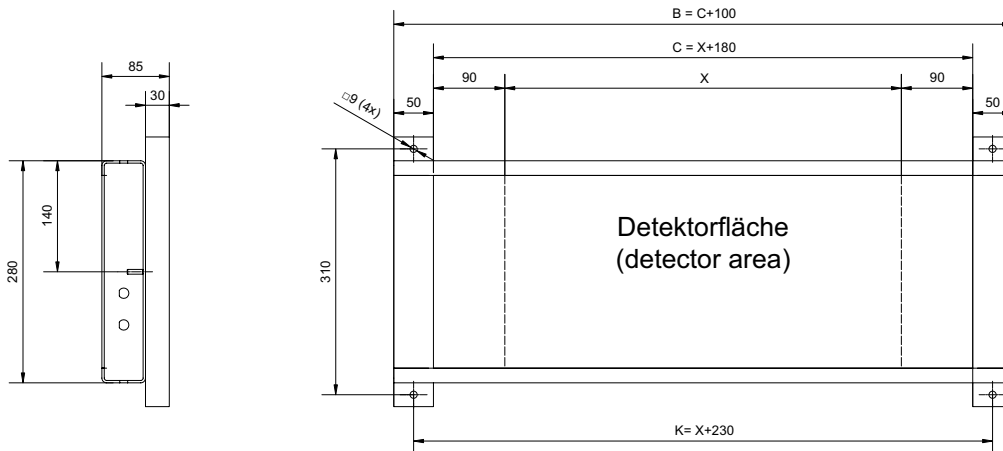

¹ The actual sensitivity depends on various factors. Unfavourable environmental conditions or vibrations can reduce the sensitivity. Conductive test material can also influence the sensitivity. For obliging information please contact our service or sales department. Our service includes product tests in our headquarters.

² Large metallic pieces can cause faulty activation even from great distances. The data refers to smaller pieces like deviating pulleys etc.. For precise information please contact our service or sales department.



p-u-l-s-o-t-r-o-n-i-c

Subject to change without notice!
Rev. 0901

Tunnel Detector M-Pulse / Digital+

BD

Application

Tunnel detectors are used where high detection capacity and reliability are requested. For operation the user chooses among various operating electronics according to his application. Thus even complex tasks can be realised. The stainless steel housing and the smoothly grouting are the advantages making this sensor first class for the use in the food industry. Products with conductive components can be faded out easily due to modern digital technology. The sensors are maintenance- and calibration free.



Tunnel Detector BD

Function

Contrary to classic metal sensors the working principle of this device is based on a system of three coils. This enables the user to analyse signals precisely and to draw conclusions on their origin. By this it is for example possible to distinguish the signals into vibration, product or metal. This additional data allows a more sensible reaction on metallic residua.

Handling

Depending on the operating electronics the handling is realised via a membrane keyboard and a LC-display. Thus all important parameters can be viewed easily and fast and changed if necessary. The sensitivity of the detector also is adjustable this way. Detailed information you will find in the documentation of the electronics M-PULSE and Digital+.

Mounting

The sensing range of the sensor partially is situated above and under the opening of the detector. Big metal pieces can already be detected in this sector. In order to guarantee the accurate functioning of the sensor, these sectors must be kept free of metal. This so-called metal-free zones are divided into two types:

- Metal-free zones for movable pieces
- Metal-free zones for non-movable pieces

The dimensions of these zones are specified in the particular data sheets.



Type	BD 100x50 .. BD 1400x750		
Mechanical data			
Sensor aperture - height	50 .. 750 mm (25 mm steps)		
Sensor aperture - width	100 .. 1400 mm (50 mm steps)		
Material	Stainless steel (Interior zone: Epoxy)		
Mounting	4x thread pin M12 x 45		
Metall free zone for static parts	1,0 x Sensor's height		
Metall free zone for moving parts ²	1,5 x Sensor's height		
Conditions of use			
Storage temperature	-10 .. 50°C		
Operating temperature	0 .. 50°C		
Protection class	IP65 (IP67 for versions HPW und LPW)		
Electrical connection	Supply via control unit; Control unit mounted directly at the sensor or optionally mounted up to 3 m away		
Sensitivity¹			
Detection height [mm]	Fe-ball	Stainless steel - ball	Used sensor
Detection height 75 mm	0,7 mm	1,4 mm	M-Pulse BD 200x75
Detection height 100 mm	0,8 mm	1,8 mm	M-Pulse BD 350x100
Detection height 150 mm	1,0 mm	2,0 mm	M-Pulse BD 350x150
Detection height 200 mm	1,2 mm	2,2 mm	M-Pulse BD 400x200
Detection height 250 mm	1,5 mm	2,5 mm	M-Pulse BD 450x250
Detection height 300 mm	1,6 mm	2,8 mm	M-Pulse BD 450x300
Detection height 350 mm	2,0 mm	2,8 mm	M-Pulse BD 600x350
Detection height 400 mm	3,0 mm	4,0 mm	M-Pulse BD 750x400

¹ The actual sensitivity depends on various factors. Unfavourable environmental conditions or vibrations can reduce the sensitivity. Conductive test material can also influence the sensitivity. For obliging information please contact our service or sales department. Our service includes product tests in our headquarters.

² Large metallic objects can cause faulty activation even from great distances. The data refers to smaller pieces like deviating pulleys etc.. For precise information please contact our service or sales department.



Dimensions

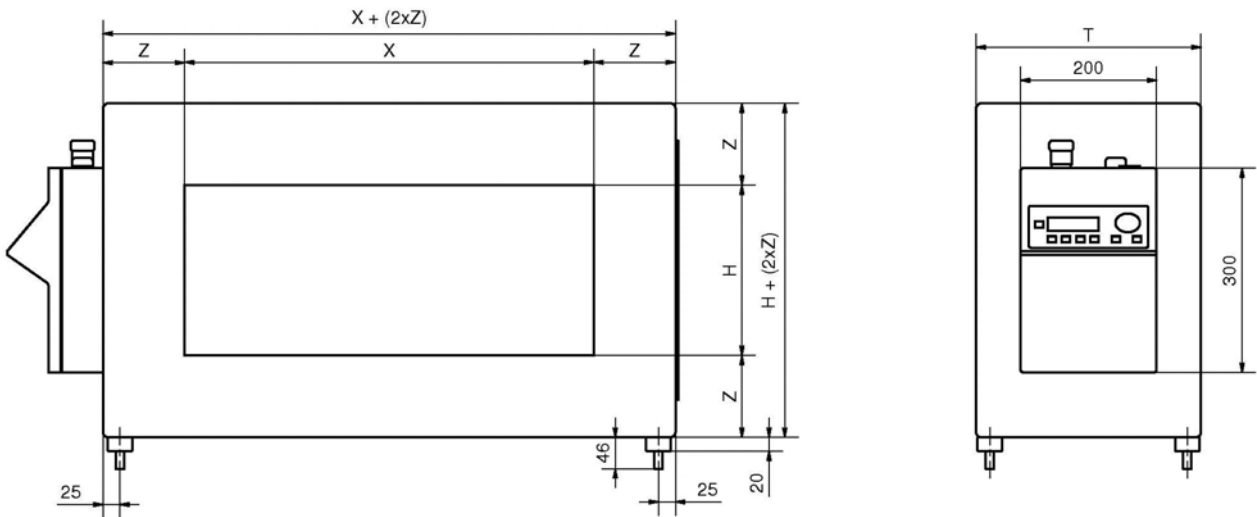

(Illustration with M-PULSE electronics)

Tunnel Detector BD

Dimension H or X (minor dimension)	Dimension T	Dimension Z
< 100 mm	available on request	available on request
101 - 175 mm	280 mm	100 mm
176 - 250 mm	330 mm	120 mm
251 - 300 mm	380 mm	140 mm
301 - 350 mm	380 mm	160 mm
351 - 400 mm	430 mm	180 mm
401 - 500 mm	470 mm	200 mm
501 - 600 mm	520 mm	220 mm
> 600 mm	available on request	available on request



Notes

Tunnel Detector BD



Subject to change without notice!
Rev. 0901

Tunnel Detector M-Pulse / Digital+

BD-SL

Application

Tunnel detectors are used where little space is available. For operation the user chooses among various operating electronics according to his application. Thus even complex tasks can be realised. The stainless steel housing and the smoothly grouting are the advantages making this sensor first class for the use in the food industry. Products with conductive components can be analysed sure and high-precision on metallic residua with modern digital technology. The sensors are maintenance- and calibration free.

Function

Contrary to classic metal sensors the working principle of this device is based on a system of three coils. This enables the user to analyse signals precisely and to draw conclusions on their origin. By this it is for example possible to distinguish the signals into vibration, product or metal. This additional data allows a more sensible reaction on metallic residua.

Handling

Depending on the operating electronics the handling is realised via a membrane keyboard and a LC-display. Thus all important parameters can be viewed easily and fast and changed if necessary. The sensitivity of the



Tunnel Detector BD-SL

detector also is adjustable this way. Detailed information you will find in the documentation of the electronics M-PULSE and Digital+.

Mounting

The sensing range of the sensor partially is situated above and under the opening of the detector. Big metal pieces can already be detected in this sector. In order to guarantee the accurate functioning of the sensor, these sectors must be kept free of metal. This so-called metal-free zones are divided into two types:

- Metal-free zones for movable pieces
 - Metal-free zones for non-movable pieces
- The dimensions of these zones are specified in the particular data sheets.



Type	BD-SL 200x100 .. BD-SL 300x600		
Mechanical data			
Sensor aperture - height	100 .. 300 mm (100 mm steps)		
Sensor aperture - width	200 .. 600 mm (100 mm steps)		
Material	Stainless steel (Interior zone: Epoxy)		
Mounting	4x thread pin M12 x 45		
Metal free zone for static parts	1,2 x Sensor's height		
Metal free zone for moving parts ²	1,75 x Sensor's height		
Conditions of use			
Storage temperature	-10 .. 50°C		
Operating temperature	0 .. 50°C		
Protection class	IP65		
Electrical connection	Supply via control unit; Control unit mounted directly at the sensor or optionally mounted up to 3 m away		
Sensitivity¹			
Detection height [mm]	Fe-ball	Stainless steel-ball	Used sensor
Detection height 100 mm	1,0 mm	2,0 mm	M-Pulse BD-SL 350x100
Detection height 200 mm	1,5 mm	2,5 mm	M-Pulse BD-SL 400x200
Detection height 300 mm	2,0 mm	3,5 mm	M-Pulse BD-SL 450x300

¹ The actual sensitivity depends on various factors. Unfavourable environmental conditions or vibrations can reduce the sensitivity. Conductive test material can also influence the sensitivity. For obliging information please contact our service or sales department. Our service includes product tests in our headquarters.

² Large metallic objects can cause faulty activation even from great distances. The data refers to smaller pieces like deviating pulleys etc. For precise information please contact our service or sales department.



Dimensions

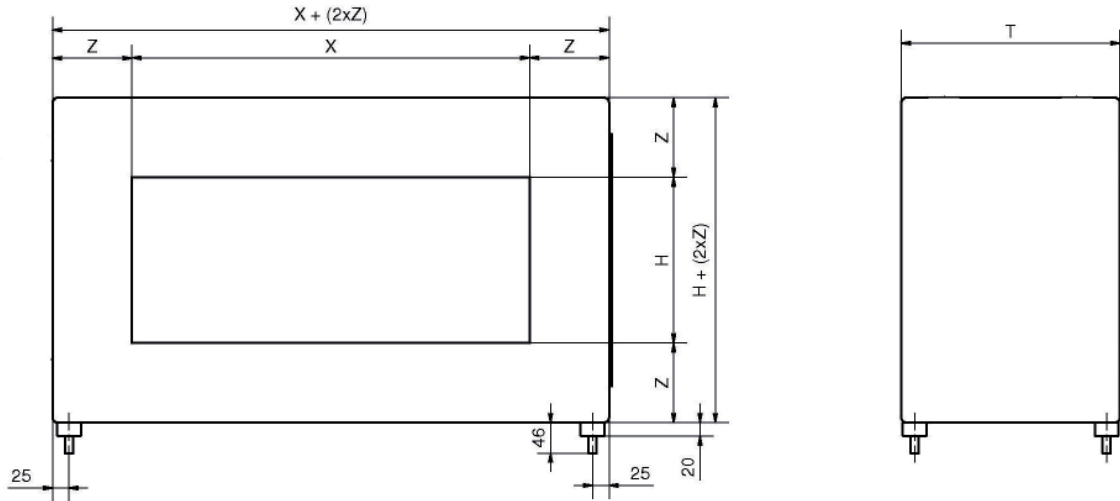

(Illustration with M-PULSE electronics)

Dimension H or X (minor dimension)	Dimension T	Dimension Z
100 mm	170 mm	60 mm
200 mm	180 mm	70 mm
300 mm	190 mm	80 mm

Tunnel Detector BD-SL



Notes

Tunnel Detector BD-SL

3.26

Pulsotronic-Anlagentechnik
GmbH

Neue Schichtstraße 7
D-09366 Niederdorf

Tel.: +49 37296 9383-500
Fax: +49 37296 9383-501

info@pulsotronic-anlagentechnik.de
www.pulsotronic-anlagentechnik.de



Subject to change without notice!
Rev. 0901

Tunnel detector (divisible) M-Pulse / Digital+

TU

Application

The TU sensor serves for retrofitting a metal detector on existing lines as well as for mounting on conveyor belts and chutes that cannot be split. Though it is possible to split the sensor for mounting and to re-assemble it afterwards, the tunnel detector TU provides highest sensitivity for metal detection. Due to this characteristics and the possible fade-out of vibrations and of the product effect the sensor can be applied almost universally. Contrary to other sensors this one is completely made of stainless steel. This allows application in the plastics as well as in the food industry.

Function

Contrary to classic metal sensors the working principle of this device is based on a system of three coils. This enables the user to analyze signals precisely and to draw conclusions on their origin. By this it is for example possible to distinguish the signals into vibration, product or metal. This additional data allows a more sensible reaction on metallic residua. The sensor is maintenance- and calibration-free.

Handling

Depending on the operating electronics the handling is realised via a membrane keyboard and a LC-display. Thus all important parameters can be viewed easily and fast and



Tunnel detector TU

changed if necessary. The sensitivity of the detector also is adjustable this way. Detailed information is stated in the documentation of the electronics M-PULSE and Digital+.

Mounting

The sensing range of the sensor partially is situated above and under the opening of the detector. Big metallic pieces can already be detected in this sector. In order to guarantee the accurate functioning of the sensor, these sectors must be kept free of metal. This so-called metal-free zones are divided into two types:

- Metal-free zones for movable pieces
 - Metal-free zones for non-movable pieces
- The dimension of these zones are specified in the particular data sheets.



Type	TU 300x100 .. TU 2500x800		
Mechanical data			
Active aperture	height: 100 .. 800 mm (50 mm steps)		
Active aperture	width: 300 .. 2500 mm (100 mm steps)		
Material	stainless steel (interior zone: epoxy)		
Mounting	4x drill hole		
Metall free zone for static parts	1,0 x sensor height		
Metall free zone for moving parts ²	1,5 x sensor height		
Conditions of use			
Storage temperature	-10 .. 50°C		
Operating temperature	0 .. 50°C		
Protection class	IP54		
Electrical connection	Supply via control unit (Attached with 3 m cable).		
Sensitivity¹			
Detection height [mm]	ferrous ball	stainless steel ball	used sensor
Detection height 200 mm	2,5	4,0	M-Pulse TU 200x200
Detection height 300 mm	3,0	5,0	M-Pulse TU 300x300
Detection height 400 mm	3,5	6,0	M-Pulse TU 600x400
Detection height 500 mm	7,0	9,0	M-Pulse TU 1000x500
Detection height 1000 mm	nut M16	nut M16	M-Pulse TU 1000x1000

Order code:

Electronic Type of sensor Dimension [mm]
M-Pulse TU sensor width X x sensor height H
Digital+

(e.g.: M-Pulse TU 1200x350)

¹ The actual sensitivity depends on various factors. Unfavourable environmental conditions or vibrations can reduce the sensitivity. Conductive test material can also influence the sensitivity. For obliging information please contact our service or sales department. Our service includes product tests in our headquarters.

² Large metallic pieces can cause faulty activation even from great distances. The data refers to smaller pieces like deviating pulleys etc.. For precise information please contact our service or sales department.



Dimensions

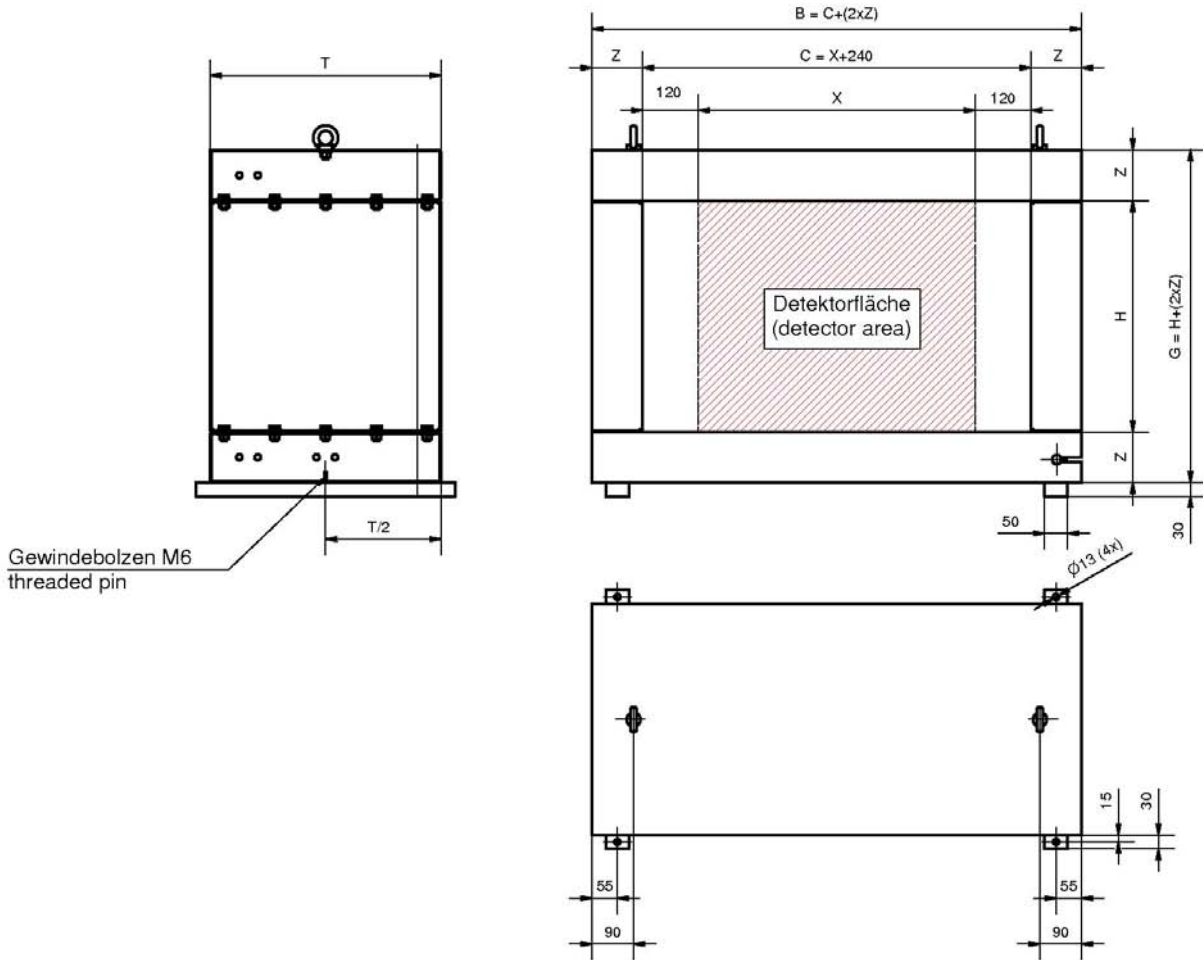

Tunnel detector TU

Dimension H	Dimension T	Dimension Z
< 175 mm	on request	on request
176 - 1000 mm	500 mm	110 mm
1001 - 1200 mm	600 mm	120 mm
> 1200 mm	on request	on request



Notes

Tunnel detector TU

3.30

Pulsotronic-Anlagentechnik
GmbH

Neue Schichtstraße 7
D-09366 Niederdorf

Tel.: +49 37296 9383-500
Fax: +49 37296 9383-501

info@pulsotronic-anlagentechnik.de
www.pulsotronic-anlagentechnik.de



Subject to change without notice!
Rev. 0901

Ring Sensors

KJR

Application

The ring sensors that are used in our metal separating systems are also applied as singular components in various branches of industry. As sensor for piece counting or for ejection control of stamping parts, for wire breakage monitoring or for the detection of metallic objects. The output signals of the ring sensors can be used for controlling, regulating, signalling or for evaluating processes. We provide a large program of ring sensors that differ in design, sensitivity or the type of the output signal.



Ring Sensors KJR

Function

A ring sensor consists of a coil with ferrite core, an oscillator, a demodulator, a signal evaluation unit and a switching amplifier (see illstr. 1). The oscillator excites a high-frequency electro-magnetic alternating field in the ring coil. Due to the ferrite core and the housing the streamlines of the field are focused and aligned in the centre of the ring. If a metallic object passes the ring sensor, turbulent flows are induced in it and thus energy is withdrawn from the field. This loss of energy causes a damping of the oscillator. The damping degree is a measure of the dimension of the metallic object. Generally there are two types of ring sensors - those with a dynamic working principle and those with a static working principle. The advantage of static sensors is their ability to detect non-moving pieces. If there is metal in the sensor range, the sensor excites a constant signal. Only when metal is removed, the signal deactivates. Static sensors serve for presence check or for the detection of large pieces. Due to their working principle their sensitivity is considerably lower than it is at dynamic sensors. Dynamic sensors only excite a short pulse when they detect metal. Metallic objects are only detected when they are moved in the sensor range. For operation normally switching amplifiers are necessary. Using them pulses can be amplified and lengthened. Large metallic objects can excite several pulses. Free-falling metallic pieces generally excite only one pulse.



Function

Similar to static sensors analog sensors excite a permanent signal. However they excite an analog voltage signal which depends on the metals' dimensions and its' position in the sensor range. Only when there is no metal left in the the sensor range, the output voltage decreases to the minimum value.

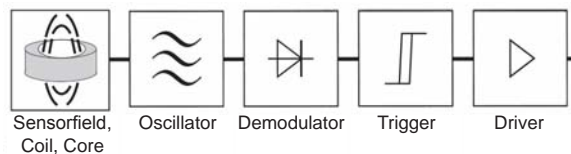

Illstr. 1: working principle of inductive ring sensors

Accessories

For operating the sensor the use of a control unit is recommendable. Our control units can be operated with 24V direct current or alternatively 24V line voltage. These devices do not only allow the regulation of the pulse length but also provide for relay outputs for high switching currents as well as transistor switching steps. The power supply for the sensors can also be realised via the control unit.

Specific characteristics

- compact and robust
- easy Initiation and operating
- wide product range
- customized solutions
- fast and competent support, delivery and service



Induktive ring sensors - Dimension Ø 12 mm

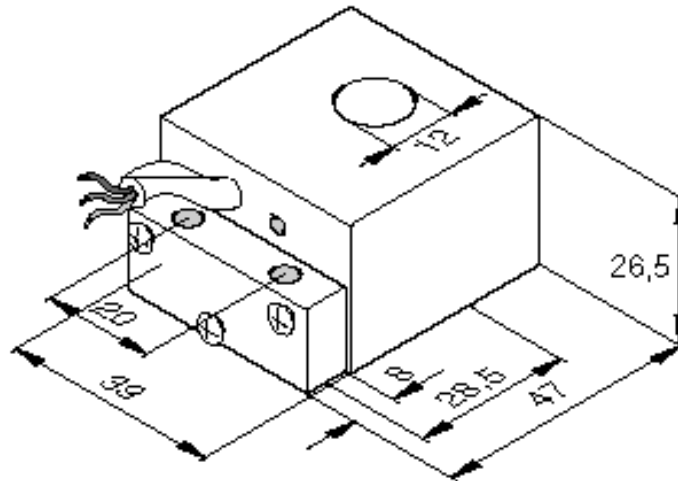

KJR-D12KN-DPS

Ring Sensors KJR

Type	KJR-D12KN-DPS
Electrical data	
Output function	Static - PNP (normally open)
Operating voltage	10 - 30 VDC
Off-state current	10 mA
Max. Load current	400 mA
Residual current	<10µA
Maximum switching frequency	800 Hz
Switching state	LED
Conditions of use	
Sensibility	FE-ball 2,5 mm
Operating temperature	-25°C .. 70°C
Protection class	IP54
Housing material	Aluminium; PUR
Electrical connection	2 m Cable; 3 x 0,34 mm ²
Order information	
Order number	08317020400



Inductive ring sensors - Dimension Ø 20 mm

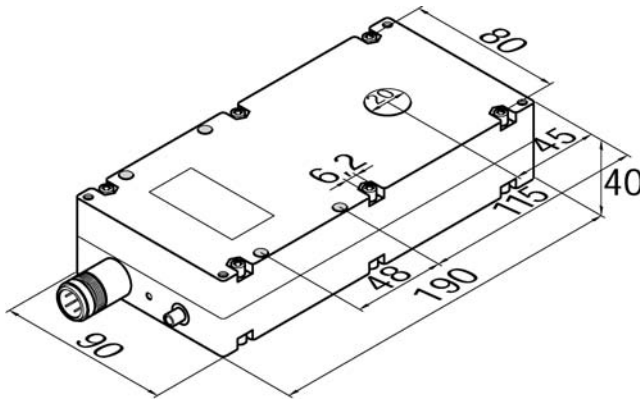

KJR-D20AN-DNIA-VE

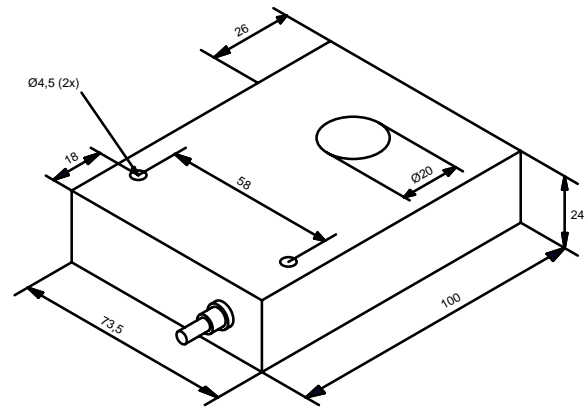

KJR-D20KN-xxx

Ring Sensors KJR

Type	KJR-D20AN-DNIA-VE	KJR-D20KN-DPS	KJR-D20KN-ANU
Electrical data			
Output function	Dynamic - NPN (changeover)	Static - PNP (normally open)	Analog [0 .. 10V]
Operating voltage	20 - 30 VDC	10 - 30 VDC	18 - 30 VDC
Off-state current	25 mA	10 mA	5 mA
Max. Load current	50 mA	200 mA	
Residual current	<50µA	<10µA	-
Maximum switching frequency	100 Hz	1000 Hz	50 Hz
Switching state	LED		
Linearity error	-		≤ ±5%
Conditions of use			
Sensibility	FE-ball 0,5 mm (adjustable)	FE-ball 6,0 mm	FE-stick 5,0 - 6,0 mm
Operating temperature	-25°C .. 70°C		
Protection class	IP54		
Housing material	Aluminium	ABS	
Electrical connection	Plug connector M12; 4-pin or Euchner plug connector	2 m Cable; 3 x 0,34 mm ²	
Order information			
Order number	08317020259	08317020500	08317142000



Inductive ring sensors - Dimension Ø 35 mm & Ø 43 mm

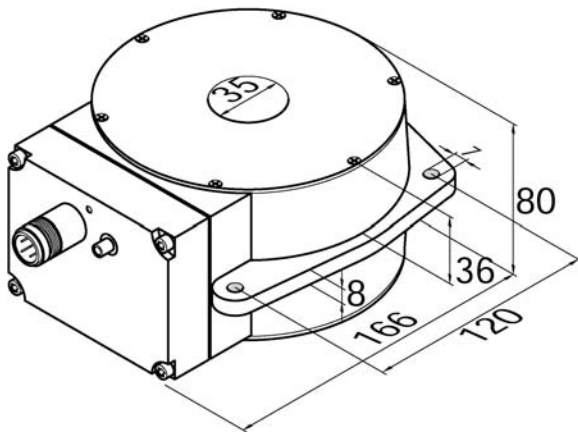

KJR-D35AN-DNIA-VE

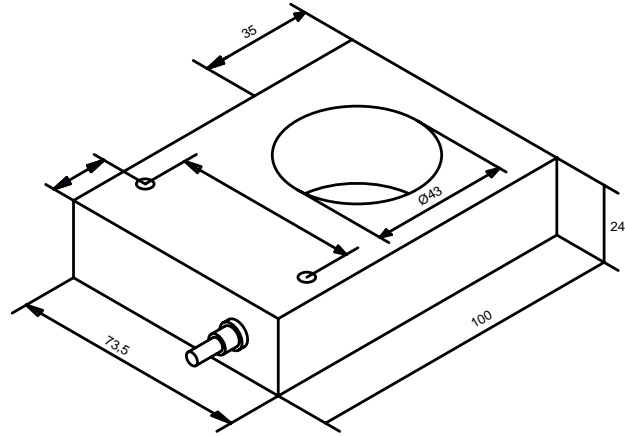

KJR-D43KN-xxx

Ring Sensors KJR

Type	KJR-D35AN-DNIA-VE	KJR-D43KN-DPS	KJR-D43KN-ANU
Electrical data			
Output function	Dynamic - NPN (changeover)	Static - PNP (normally open)	Analog [0 .. 10V]
Operating voltage	20 - 30 VDC	10 - 30 VDC	18 - 30 VDC
Off-state current	25 mA	10 mA	1 mA
Max. Load current	50 mA	200 mA	5 mA
Residual current	<50µA	<10µA	<1µA
Maximum switching frequency	100 Hz	500 Hz	50 Hz
Switching state	LED		
Conditions of use			
Sensibility	FE-ball 0,5 mm (adjustable)	FE-ball 9,0 mm	FE-stick 1,0 - 20 mm
Operating temperature	-25°C .. 70°C		
Protection class	IP54		
Housing material	Aluminium	ABS	
Electrical connection	Plug connector M12; 4-pin or Euchner plug connector	2 m Cable; 3 x 0,34 mm ²	
Order information			
Order number	08317130059	08317050500	08317144300



Inductive ring sensors - Dimension Ø 50 mm

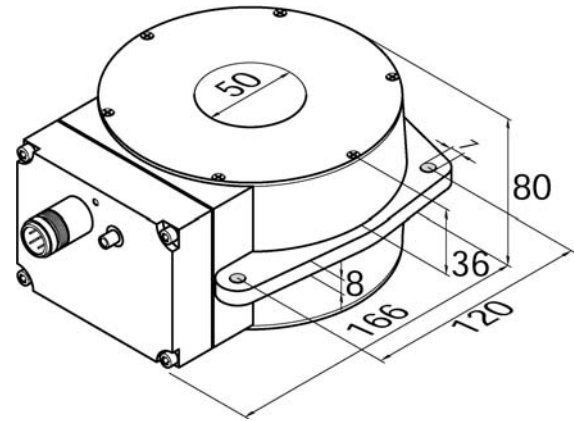
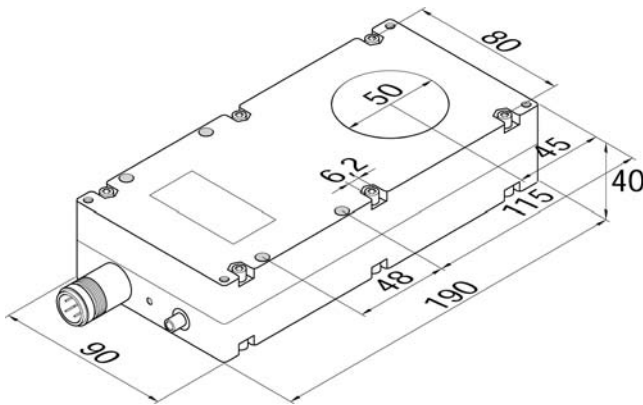

KJR-D50FAN-DNIA-VE
KJR-D50AN-DxA-Vx

KJR-D50AN-DNIA-Vx

Ring Sensors KJR

Type	KJR-D50AN-DNA-Vx	KJR-D50AN-DPA-Vx	KJR-D50AN-DNIA-Vx	KJR-D50FAN-DNIA-VE
Electrical data				
Output function	Static - NPN (changeover)	Static - PNP (changeover)	Dynamic - NPN (changeover)	Dynamic - NPN (changeover)
Operating voltage	10 - 30 VDC		20 - 30 VDC	
Off-state current	15 mA		25 mA	
Max. Load current	200 mA		50 mA	
Residual current	<10µA		<50µA	
Maximum switching frequency	500 Hz		100 Hz	
Switching state	LED			
Conditions of use				
Sensibility	FE-ball 3,0 mm		FE-ball 0,6 mm	FE-ball 1,0 mm
Operating temperature	-25°C .. 70°C			
Protection class	IP54			
Housing material	Aluminium			
Electrical connection	Plug connector M12; 4-pin or Euchner plug connector			Euchner plug connector
Order information				
order number (M12)	on request	on request	08317010765	-
order number (Euchner)	08317050259	08317050659	08317010759	08317010259



p-u-l-s-o-t-r-o-n-i-c

Inductive ring sensors - Dimension Ø 70 mm

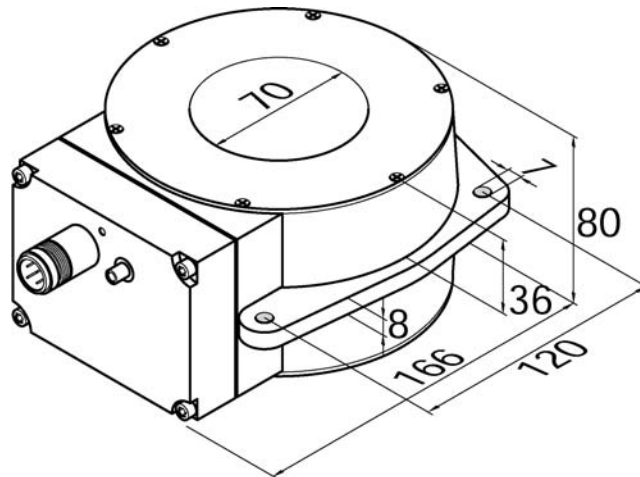

Ring Sensors KJR

KJR-D70AN-DNIA-VE

Type	KJR-D70AN-DNIA-VE
Electrical data	
Output function	Dynamic - NPN (changeover)
Operating voltage	20 - 30 VDC
Off-state current	25 mA
Max. Load current	50 mA
Residual current	<50µA
Maximum switching frequency	100 Hz
Switching state	LED
Conditions of use	
Sensibility	FE-ball 1,0 mm (adjustable)
Operating temperature	-25°C .. 70°C
Protection class	IP54
Housing material	Aluminium
Electrical connection	Plug connector M12; 4-pin or Euchner plug connector
Order information	
Order number	08317110059



Inductive ring sensors - Dimension Ø 100 mm

Ring Sensors KJR

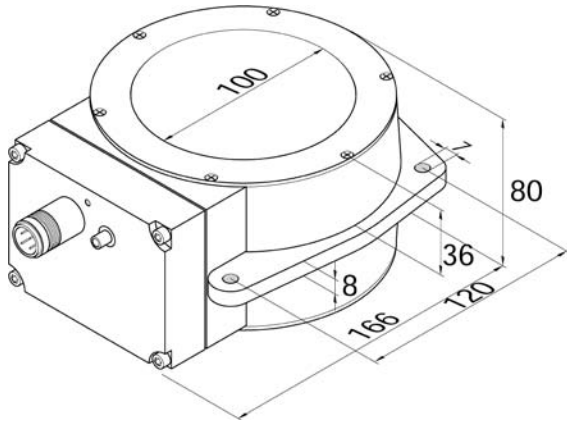

KJR-D100AN-DxA-Vx

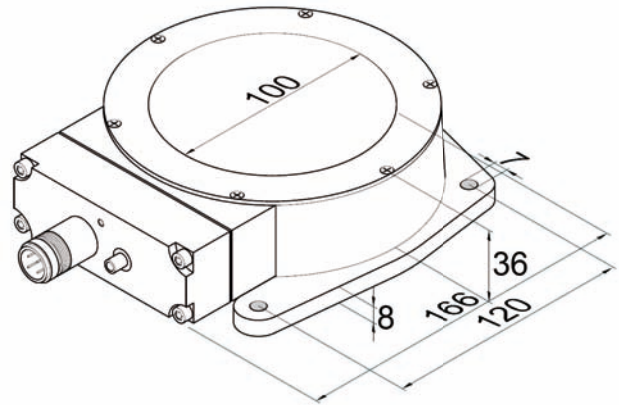

KJR-D100FAN-DxA-VE

Type	KJR-D100FAN-DNA-Vx	KJR-D100FAN-DPA-Vx	KJR-D100AN-DNA-Vx	KJR-D100AN-DPA-Vx
Electrical data				
Output function	Static - NPN (changeover)	Static - PNP (changeover)	Static - NPN (changeover)	Static - PNP (changeover)
Operating voltage	18 - 30 VDC		10 - 30 VDC	
Off-state current	15 mA		10 mA	
Max. Load current	200 mA			
Residual current	<10µA			
Maximum switching frequency	500 Hz			
Switching state	LED			
Conditions of use				
Sensibility (adjustable)	FE-ball 8,0 mm		FE-ball 6,0 mm	
Operating temperature	-10°C .. 60°C			
Protection class	IP54			
Housing material	Aluminium			
Electrical connection	Plug connector M12; 4-pin or Euchner plug connector			
Order information				
Order number (M12)	on request	on request	on request	on request
Order num. (Euchner)	08317080059	08317080559	08317080159	08317080659



Inductive ring sensors - Dimension Ø 100 mm (continuation)

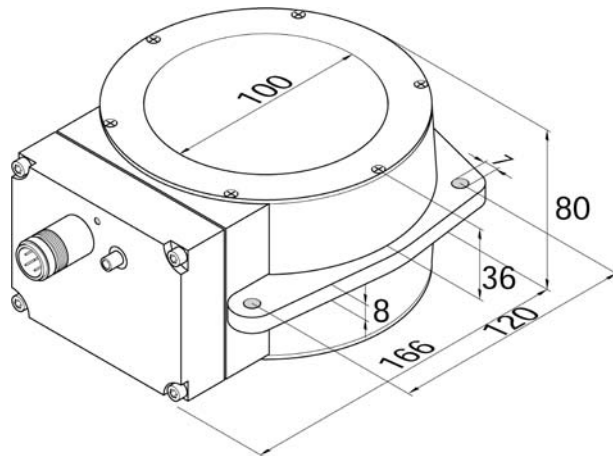

KJR-D100AN-DNIA-Vx

Ring Sensors KJR

Type	KJR-D100AN-DNIA-Vx
Electrical data	
Output function	Dynamic - NPN (changeover)
Operating voltage	20 - 30 VDC
Off-state current	25 mA
Max. Load current	50 mA
Residual current	<50µA
Maximum switching frequency	100 Hz
Switching state	LED
Conditions of use	
Sensibility	FE-ball 1,3 mm (adjustable)
Operating temperature	-25°C .. 70°C
Protection class	IP54
Housing material	Aluminium
Electrical connection	Plug connector M12; 4-pin or Euchner plug connector
Order information	
Order number (M12)	08317000165
Order num. (Euchner)	08317000159



Inductive ring sensors - Dimension Ø 200 mm

Ring Sensors KJR

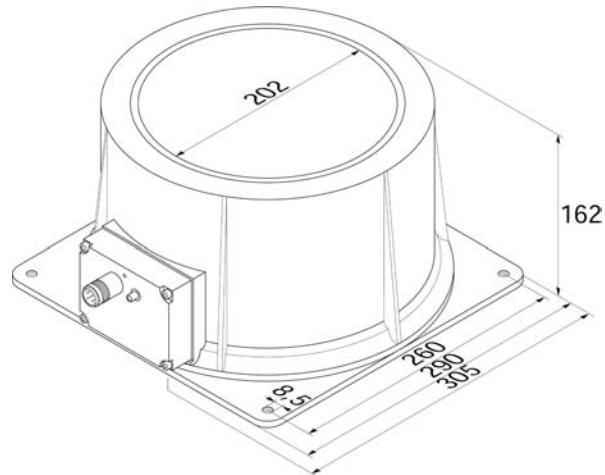

KJR-D200AN-xxx

Type	KJR-D200AN-DNA-Vx	KJR-D200AN-DPA-Vx	KJR-D200AN-DNIA-VE
Electrical data			
Output function	Static - NPN (changeover)	Static - PNP (changeover)	Dynamic - NPN (changeover)
Operating voltage	10 - 30 VDC		20 - 30 VDC
Off-state current	10 mA		25 mA
Max. Load current	200 mA		50 mA
Residual current	<10µA		<50µA
Maximum switching frequency	300 Hz		100 Hz
Switching state	LED		
Conditions of use			
Sensibility	FE-Kugel - 15 mm		FE-Kugel - 3,0 mm
Operating temperature	-10°C .. 60°C		-25°C .. 70°C
Protection class	IP54		
Housing material	Aluminium		
Electrical connection	Plug connector M12; 4-pin or Euchner plug connector		
Order information			
Order number (M12)	on request	08317160665	-
Order num. (Euchner)	08317060159	08317060659	08317030159



Inductive ring sensors - Dimension Ø 300 mm

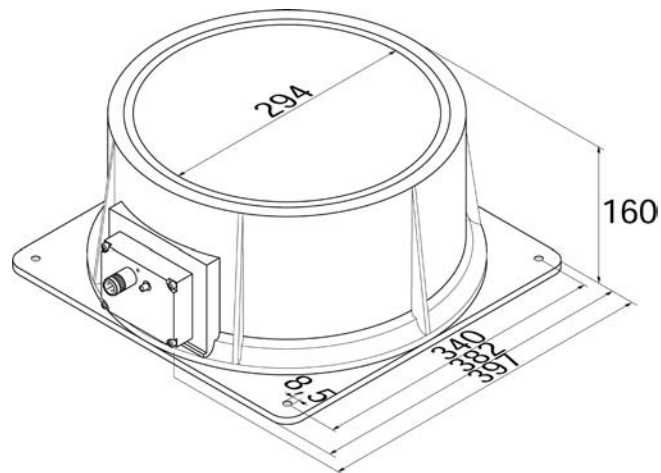

KJR-D300AN-xxx

Ring Sensors KJR

Type	KJR-D300AN-DNA-VE	KJR-D300AN-DPA-Vx	KJR-D300AN-DNIA-VE
Electrical data			
Output function	Static - NPN (changeover)	Static - PNP (changeover)	Dynamic - NPN (changeover)
Operating voltage	10 - 30 VDC		20 - 30 VDC
Off-state current	10 mA		25 mA
Max. Load current	200 mA		50 mA
Residual current	<10µA		<50µA
Maximum switching frequency	300 Hz		100 Hz
Switching state	LED		
Conditions of use			
Sensibility	FE-ball - 30 mm		FE-ball - 4,0 mm
Operating temperature	-10°C .. 60°C		-25°C .. 70°C
Protection class	IP54		
Housing material	Aluminium		
Electrical connection	Plug connector M12; 4-pin or Euchner plug connector		
Order information			
Order number (M12)	-	08317070665	-
Order num. (Euchner)	08317070159	08317070659	08317040159



Inductive square sensors - Dimensions 130 mm & 290 mm

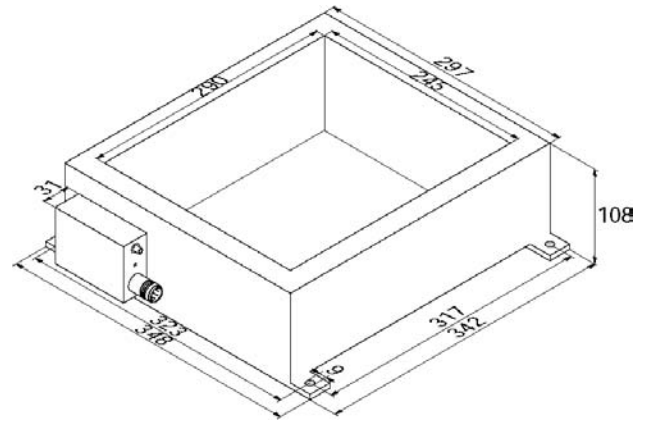
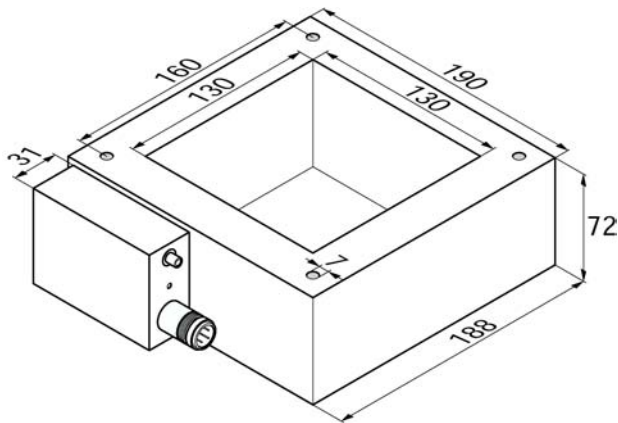

KJR-Q130AN-DxA-VE
KJR-Q130AN-DNIA-VE

KJR-Q290AN-DNIA-VE

Ring Sensors KJR

Type	KJR-Q130AN-DNA-VE	KJR-Q130AN-DPA-VE	KJR-Q130AN-DNIA-VE	KJR-Q290AN-DNIA-VE
Electrical data				
Output function	Static - NPN (changeover)	Static - PNP (changeover)	Dynamic - NPN (changeover)	Dynamic - NPN (changeover)
Operating voltage	10 - 30 VDC		20 - 30 VDC	
Off-state current	10 mA		25 mA	
Max. Load current	50 mA			
Residual current	<10µA		<500µA	
Maximum switching frequency	300 Hz		100 Hz	
Switching state	LED			
Conditions of use				
Sensibility (adjustable)	FE-ball 12 mm		FE-ball 5,0 mm	FE-ball 12 mm
Operating temperature	-10°C .. 60°C		-25°C .. 70°C	
Protection class	IP54			
Housing material	Aluminium			
Electrical connection	Plug connector M12; 4-pin or Euchner plug connector			
Order information				
Order number	08317090159	08417090659	08317090359	08317090259



Remarks

As long as there are no other specifications all sensors from Pulsotronic have the following characteristics:

- switching outputs with short circuit protection and overload protection
- reverse voltage protection of all connections
- EMV-conformity according to EN 60947-5-2; 2004

Accessories

Designation	Article number
Control unit	
230 VAC; 24 VDC	08349005011
115 VAC; 24 VDC	08349005013
Connecting cable	
connecting cable 2 m f. connection to M12	44505125310
connecting cable 5 m f. connection to M12	44505125312
connecting cable 2 m f. connection to M12 (right-angle plug)	44505123910
connecting cable 5 m f. connection to M12 (right-angle plug)	44505123912
connecting cable 2 m f. connection to Euchner	44505120200
connecting cable 5 m f. connection to Euchner	44505120202



Notes

Ring Sensors KJR

3.44

Pulsotronic-Anlagentechnik
GmbH

Neue Schichtstraße 7
D-09366 Niederdorf

Tel.: +49 37296 9383-500
Fax: +49 37296 9383-501

info@pulsotronic-anlagentechnik.de
www.pulsotronic-anlagentechnik.de



Subject to change without notice!
Rev. 0901

Ring sensor M-Pulse / Digital+

RG

Application

This ring detector is used in our metal separators as well as in many other branches of industry. In applications in which the performance of analog ring sensors is not sufficient the detectors of the RG series do have great advantages due to their capacity. Especially the extremely high sensitivity and the possibility to eliminate product effects with the appropriate electronics allow outstanding solutions in the fields machine protection, process control and monitoring.

Handling

Depending on the electronics operation is realised via a membrane keyboard and a LC-display. By this all important parameters can be displayed and if necessary changed easily. The sensitivity of the sensor also is adjustable this way. Precise information is stated in the documentation of the operating electronics M-PULSE and Digital+.

Function

Contrary to classical metal sensors the working principle of this detector is based on a system of three coils. This enables the user to analyse signals precisely and to draw conclusions on their origin. By this it is for example possible to distinguish the signals into vibrati-

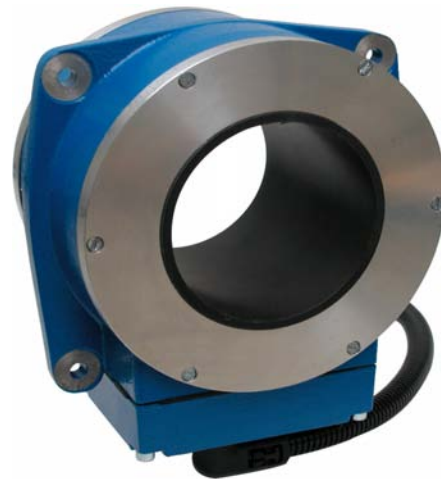

Ring sensor RG

on, product or metal. This additional data allows a more sensible reaction on metallic residues. The sensors do not require maintenance or calibration.

Mounting

The sensing range of the sensor partially is situated above and under the opening of the detector. Big metal pieces can already be detected in this sector. In order to guarantee the accurate functioning of the sensor, these sectors must be kept free of metal. This so-called metal-free zones are divided into two types:

- Metal-free zones for movable pieces
- Metal-free zones for non movable pieces

The dimensions of these zones are specified in the particular data sheets.



Ring sensor RG

Type	RG 25	RG 35	RG 50	RG 70	RG 100					
Mechanical data										
Height	95 mm				120 mm					
Inner diameter - D	25 mm	35 mm	50 mm	70 mm	102 mm					
Metal free zone for static parts	1 x inner diameter									
Metal free zone for moving parts	1,5 x inner diameter									
Conditions of use										
Storage temperature	-10 .. 60°C									
Operating temperature	0 .. 60°C									
Protection class	IP54									
Electrical connection	Supply via control unit (Attached with 3 m cable).									
Sensitivity¹										
Material - test pieces ²	FE	SS	FE	SS	FE	SS	FE	SS	FE	SS
M-Pulse	0,15	0,4	0,2	0,5	0,3	0,7	0,5	1,0	0,7	1,2
Digital+	0,2	0,5	0,3	0,6	0,35	0,9	0,6	1,1	0,8	1,3

Order code:

electronic

M-Pulse / Digital+

type of sensor

RG 25 - RG 100

(e.g.: Digital+ RG 70)

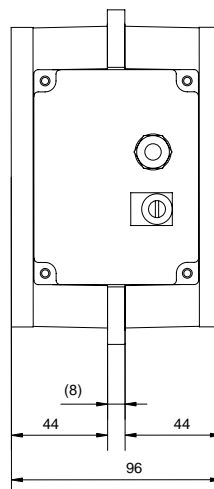
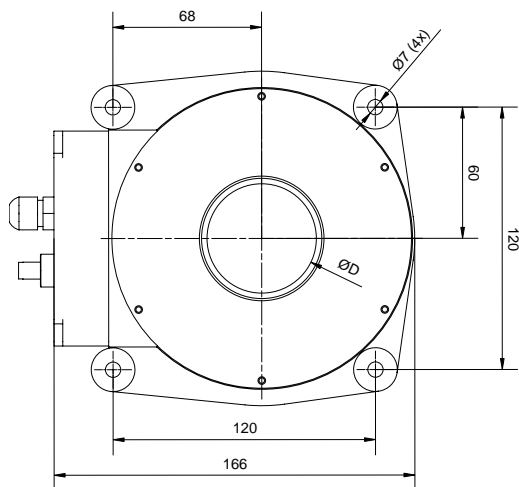

(Drawing for RG 100 on request)

¹ The actual sensitivity depends on various factors. Unfavourable environmental conditions or vibrations can decrease the sensitivity, as well as conductive test material can influence it. For precise information please contact our service or sales department. Our service includes product tests in our headquarters.

² FE → Ferrous / SS → Stainless steel

3.46

Pulsotronic-Anlagentechnik
GmbH

Neue Schichtstraße 7
D-09366 Niederdorf

Tel.: +49 37296 9383-500
Fax: +49 37296 9383-501

info@pulsotronic-anlagentechnik.de
www.pulsotronic-anlagentechnik.de



Subject to change without notice!
Rev. 0901

Ring Sensors M-Pulse / Digital+

KS

Application

This sensor was designed especially for use in injection moulding machines. The finished injection moulded parts are directly conveyed to the sensor after leaving the machine. The sensor reliably detects even the tiniest metal contaminations, which could be caused by nicks or pieces that have broken off the die. Thus, faults can be detected early enough to protect subsequent machines such as fabrication machines from any damages. The sensor is easily mounted using a fastening frame. This can be precisely adapted in accordance with your requirements.



Ring Sensors KS

Function

The material running in via a conveyor belt or vibrating trough is conveyed through the sensor via the funnel. If metal falls through the sensor, then the signal is detected and processed by the evaluation electronics. The electronics are able to detect the tiniest metal pieces and reliably blend out any interfering signals. If metal is detected, then this can be signalled by an acoustic or visual transmitting device. The electronics are located in a separate housing. A 3 meter long connection cable links the electronics to the sensor. Thus, the electronics can always be fastened in an ergonomically favourable position, making the unit handy to operate, even in the event of unfavourable space conditions.

Specific characteristics

- Detects tool steel from 0.5 mg up
- Offset electronics
- Available with various internal widths
- Compact design
- Customer-specific fastening frame
- Sturdy, calibration-free sensor
- Powerful electronics with product effect fade-out



Type	KS 100	
Mechanical data		
Height	210 mm (plus fining rack)	
Aperture	90 mm	
Hopper	300 x 400 mm	
Material-hopper	PVC	
Weight	~ 10 kg	
Conditions of use		
Storage temperature	-10 .. 60°C	
Operating temperature	0 .. 60°C	
Electrical connection	IP65	
Connection	Supply via control unit (Attached with 3 m cable)	
max. drop height of the bulk material	0 .. 600 mm (from top of device)	
Sensitivity¹		
Material - test pieces	ferrous-ball	stainless steel-ball
M-Pulse	0,5 mm	1,0 mm
Digital+	0,5 mm	1,2 mm

Order code:

Electronic

M-Pulse / Digital+

Type of separator

KS 100

(z.B.: Digital+ KS 100)

Models with different dimensions for the funnel and internal widths available on request!

¹ The actual sensitivity is dependent on various factors. It can be negated by unfavourable ambient conditions or vibrations. Conductive test material can also affect the sensitivity. For further information, please contact our Service or Sales Departments. We would be pleased to perform a product study for you.



Application example



Ring Sensors KS

The Digital+ KS 100 for controlling nuclear fragments on downstream conveyor belts to injection moulding machines. (Illustration showing upstream tunnel detector)



Dimensions

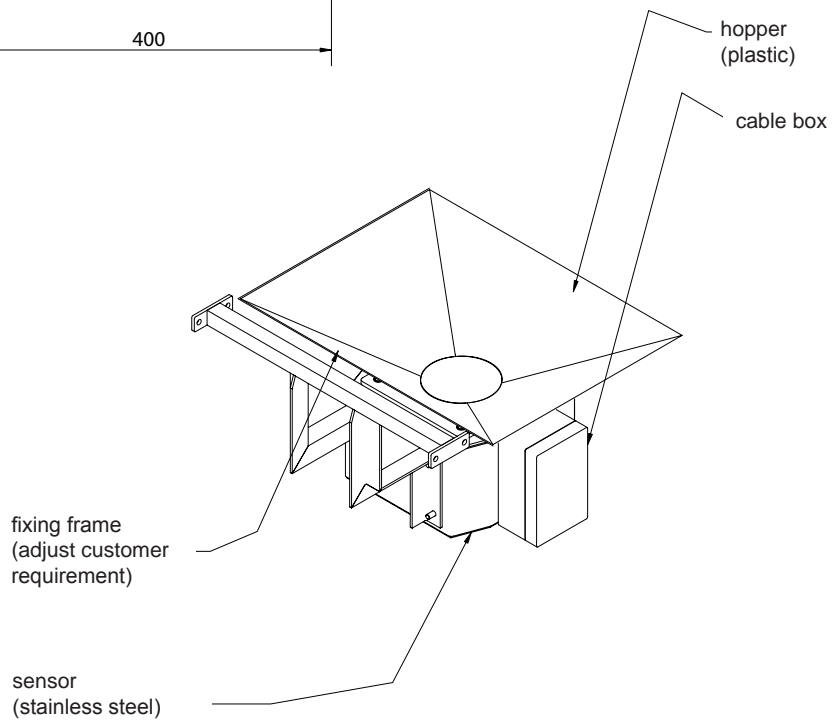
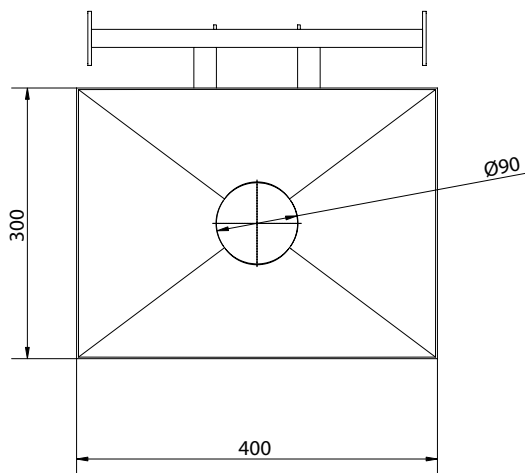
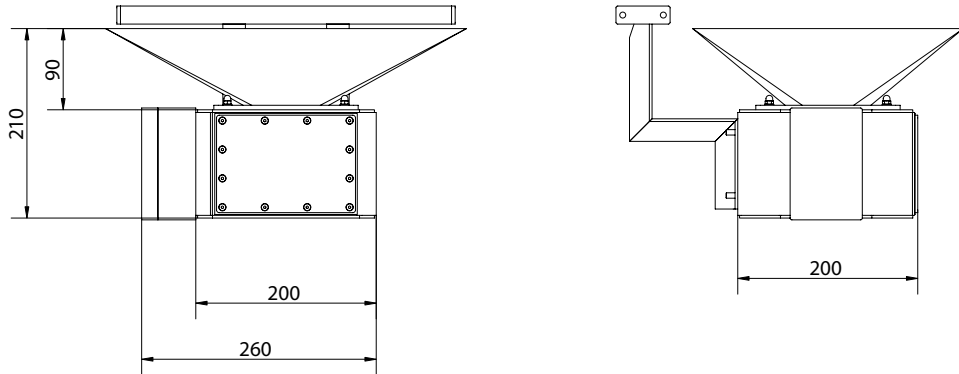

Ring Sensors KS

3.50

Pulsotronic-Anlagentechnik
GmbH

Neue Schichtstraße 7
D-09366 Niederdorf

Tel.: +49 37296 9383-500
Fax: +49 37296 9383-501

info@pulsotronic-anlagentechnik.de
www.pulsotronic-anlagentechnik.de



Subject to change without notice!
Rev. 0901

Control unit for ring sensors

Application

The control unit for ring sensors can be operated with all detectors of the KJR series. It not only serves for evaluating the ring sensors' signals but also realises the voltage supply for the sensor. It is designed specially for mounting on a 35 mm top hat rail. The device additionally can be operated with all switching sensors and with 24 V operating voltage.

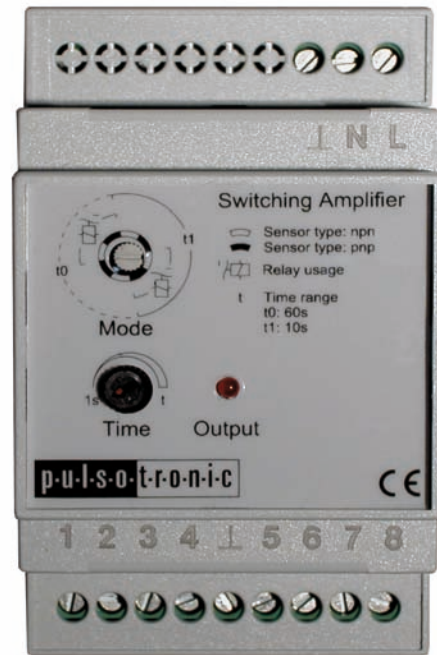

Control unit for ring sensors

Function

If the connected sensor excites a signal, it will be collected and lengthened on the adjusted period by the control unit. When during that time another signal is excited, it will be lengthened on the adjusted period again. After that the signal is output via a relay and a transistor output. The active switching state is indicated by an LED. The device can be operated with 24V direct current or alternatively with line voltage. All outputs provide short circuit protection as well as overload protection. All voltage inputs are protected against reverse polarity.

Handling

The period for a switching pulse is adjusted via a potentiometer. For a more exact adjustment the user chooses among two time ranges. The adjustment of the time domain is effected via a rotary coding switch. Via this switch the user also defines if the relay shall be activated or if the connected sensor is NPN or PNP switching. Changeover sensors don't need an adjustment for NPN or PNP.



Control unit for ring sensors

Type	Control unit for ring sensors 230 VAC / 24 VDC	Control unit for ring sensors 115 VAC / 24 VDC
Mechanical data		
Dimension	L x B x H: 90 x 53 x 58 mm	
Weigth	290 g	
Mounting	35 mm - top hat rail	
Electrical data		
Supply voltage	230 V; 50/60 Hz bzw. 24 VDC	115 V; 50/60 Hz bzw. 24 VDC
Supply for sensor	24 VDC; max. 80 mA (overload and short-circuit proof)	
Low power output	1 x low-side/open-collector; 1 x high-side/open-collector; 20 mA; (overload and short-circuit proof)	
Relay output	1 x change-over contact; max 250 VAC, 5 A	
Pulse duration	0,01 .. 0,6 / 0,1 .. 60 s (adjustable)	
Conditions of use		
Storage temperature	-10°C .. 60°C	
Operating temperature	-10°C .. 50°C	
Protection class	IP20	
Order information		
Order number	08349005011	08349005013
Cable set for sensors	2 m	5 m
with plug M12	44505125310	44505125312
with plug Euchner	44505120200	44505120202

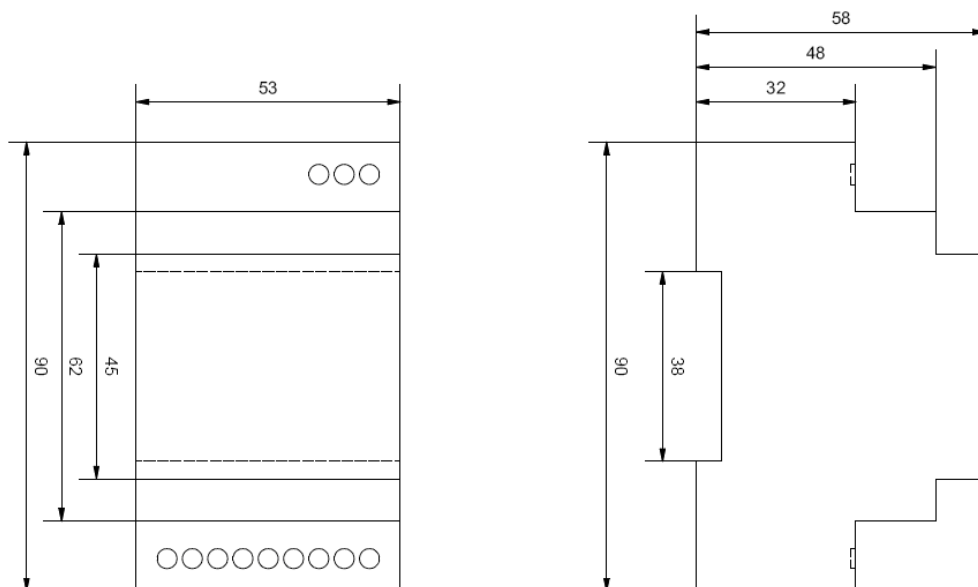



Subject to change without notice!
Rev. 0901

Control unit for flat sensors

Application

This control unit can be operated with all flat detectors of the series MESEP SP, MESEP RE and MESEP AR. By a decoder switch the control unit can be adapted easily to the sensor and the application. The supply voltage for the sensor is provided by the device. The control unit can be mounted on a 35 mm top hat rail.

Function

If the connected flat sensor excites a signal, it will be collected and lengthened on the adjusted period by the control unit. When during that time another signal is excited, it will be lengthened on the adjusted period again. After that the signal is output via a relay and a transistor output. The active switching state is indicated by an LED. Drift effects on the sensor caused by deterioration or thermal fluctuation are balanced by the control unit. The device can be operated with 24V direct current or alternatively with line voltage. The voltage supply for the sensor is realised directly via the control unit. All outputs provide short circuit protection as well as overload protection. All voltage inputs are protected against reverse polarity.



Control unit for flat sensors

Handling

The period for a switching pulse and the sensitivity can be adjusted via a potentiometer. For a more exact adjustment the user chooses among two time ranges. The adjustment of the time domain is effected via a rotary coding switch. Via this switch the user also defines if the relay shall be activated. Furthermore the switch serves for the selection of the appropriate speed range. Altogether there are four different ranges from minimum 10 m/min up to maximum 150 m/min.



Control unit for flat sensors

Type	Control unit for flat sensors 230 VAC / 24 VDC	Control unit for flat sensors 115 VAC / 24 VDC
Mechanical data		
Dimension	L x B x H 90 x 53 x 58 mm	
Weigth	290 g	
Mounting	35 mm - top hat rail	
Electrical data		
Supply voltage	230 V; 50/60 Hz or 24 VDC	115 V; 50/60 Hz or 24 VDC
Supply for sensor	15 VDC; max. 80 mA (overload and short-circuit proof)	
Low power output	1 x low-side/open-collector; 1 x high-side/open-collector; 20 mA (overload-and short-circuit proof)	
Relay output	1 x change-over contact; max 250 VAC, 5 A	
Speed	1-10 / 1-30 / 1-100 / 1-150 m/min	
Pulse duration	1 .. 10 s / 1 .. 60 s (adjustable)	
Condition of use		
Storage temperature	-10°C .. 60°C	
Operating temperature	-10°C .. 50°C	
Protection class	IP20	
Order information		
Order number	08349005010	08349005012

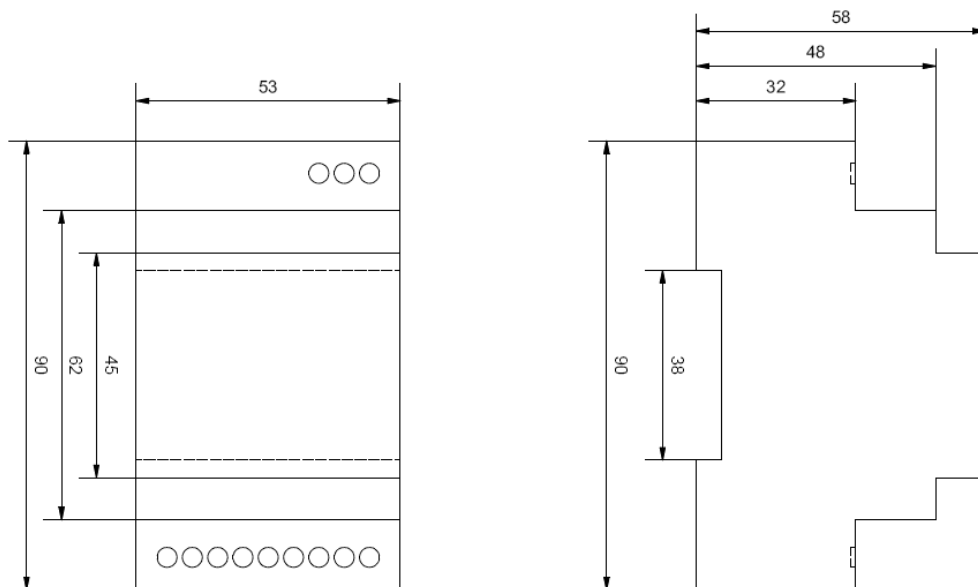



Subject to change without notice!
Rev. 0901

Control unit for flat sensors (10-channel)

Application

This control unit can be operated with all flat detectors of the series MESEP SP, MESEP RE and MESEPAR. The unit particularly is appropriate for applications in which flat sensors detect the test material transported on conveyor belts or chutes on metallic contamination and separate it subsequently. The control of the conveyor belt can be realised directly by the control unit. The device provides 10 inputs and can either analyse large SP faces or several AR faces. The control unit is operated with 24VDC or with line voltage. It is available in three versions. The model with reversing contactor circuit allows the complete control of three-phase-motors. For this reason the device can be applied worldwide in all branches of industry.

Function

If one of the connected sensors (max. 10) sends a signal this will be evaluated by the device. Thus the control unit can for example stop the belt or activate the reverse motion of the belt. After this the belt restarts - automatically or by pushing the start button. The actual state is indicated by two signal lights. By the reverse motion the user can make sure that really all metallic pieces have been removed. If any metallic residua is not removed from the belt, it passes the detector again and will be detected. This will be repeated until the contamination has been removed.



Control unit for flat sensors

Handling

On the device there are buttons for Start, Stop and for actuating alarms. Two potis in the inside of the control unit realise the adjustment of the sensitivity as well as the time. Via DIP-switch further features as automatic belt motion, the belt speed and time domains can be adjusted.



Type	standard	with reverting conductor	for top hat rail
Mechanical data			
Dimension	200 x 200 x 80 mm	200 x 300 x 80 mm	195 x 125 x 67 mm
Weigth	2500 g	3500 g	425 g
Mounting	4 x fixing hole Ø6	4 x fixing hole Ø8	35 mm - top hat rail
Housing	metal - powder coated	stainless steel	plastic
Electrical data			
Supply voltage	110 VAC - 250 VAC; 50/60 Hz or 24 VDC		
Supply for sensors	15 VDC; max. 120 mA (overload- and short-circuit proof)		
Low power output	1 x high-side/open-collector; max. 20 mA (overload- and short-circuit proof)		
Relay output	1 x change-over contact; max 250 VAC, 5 A		
Speed	1-10 / 1-30 / 1-100 / 1-150 m/min		
Puls duration	1 .. 60 s		
Reverting conductor	-	3phase380 VAC; 9 A	-
Conditions of use			
Storage temperature	-10°C .. 60°C		
Operating temperature	-10°C .. 50°C		
Protection class	IP54	IP65	IP20
Order information			
Order number	08349005000	08349005002	08349005001

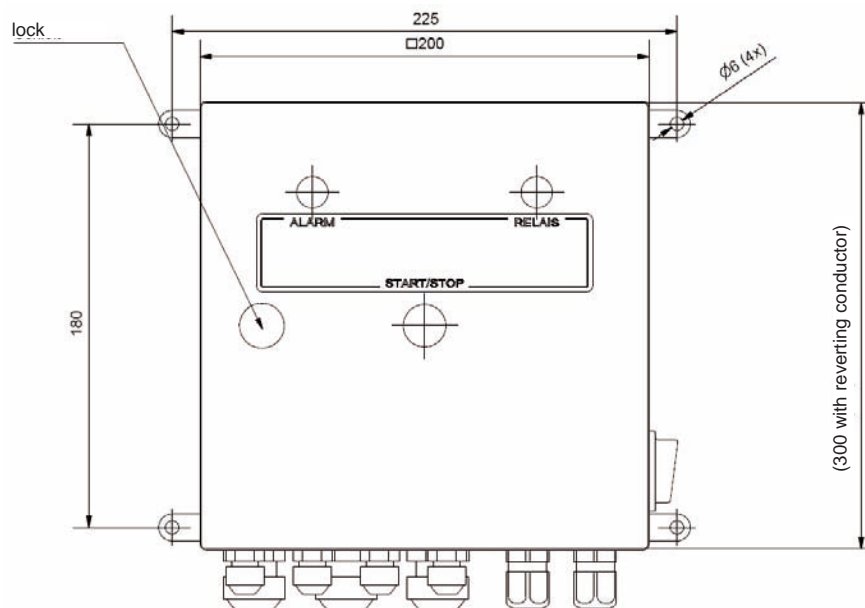



Subject to change without notice!
Rev. 0901

Metal separator M-Pulse / Digital+ MESEP

Extraktor

Application

These separators are used for different applications in the plastics industry. The Extraktor has been developed exclusively for the operation on suction conveyors. The entire path through the Extraktor is completely airtight. Thus for example injection moulding machines with automatic feeding via a suction conveyor can be protected efficiently. The device is available in seven different connection types. Therefore the Extraktor can be operated with nearly each suction conveyor.



Metal separator Extraktor

Function

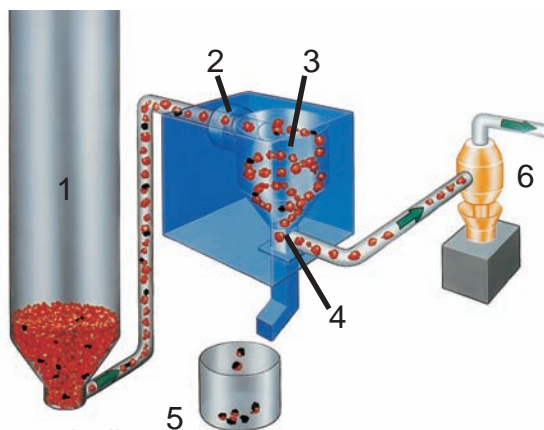

- 1 - stock silo
- 2 - sensor
- 3 - cyclone
- 4 - separating filter
- 5 - special outlet for metallic residua
- 6 - suction conveyor

The suction conveyor sucks the material through the Extraktor. Thereby the material passes the sensor, streams afterwards through a cyclone and finally quits the device through a separating filter. If metal is detected, the filter opens and metal is led out. Simultaneously the sensor and the cyclone are blown out with compressed air in order to eliminate potentially left metallic residua. After that the separating filter is closed and the feeding continues. This mechanism is fully independent of the stream velocity. The correct functioning of the mechanics can be checked at the push of a button.



p-u-l-s-o-t-r-o-n-i-c

Metal separator Extraktor

Type	Extraktor 38 - 70						
	38	45	50	55	60	65	70
Mechanical data							
Dimensions	L x W x D: 450 x 450 x 300 mm						
Outer diameter of the inlet and outlet nozzle	38 mm	45 mm	50 mm	55 mm	60 mm	65 mm	70 mm
Material-ejection unit	stainless steel						
Material-base frame	ferrous						
Material-protection tube ²	PU & phenolic resin						
Material-gasket	Linatex						
Weigth	~ 32 kg						
Conditions of use							
Storage temperature	-10°C .. 60°C						
Operating temperature	0°C .. 60°C						
Protection class	IP50						
Electrical connection	see datasheet of the control unit						
Pneumatic connection	4-6 bar, filtered, free of water & oil; self-sealing-coupling - fitting NW 7,2						
Troughput ³	600 l/h	1.000 l/h	1.300 l/h	1.700 l/h	2.200 l/h	2.700 l/h	3.300 l/h
Sensitivity¹							
Material - test pieces	Fe ⁴	SS ⁴	Fe	SS			
M-Pulse	0,3 mm	0,9 mm	0,5 mm	1,0 mm			
Digital+	0,35 mm	1,1 mm	0,6 mm	1,1 mm			
MESEP	0,6 mm	1,2 mm	1,0 mm	1,5 mm			

Ordering code:

Elektronic

M-Pulse / Digital+ / MESEP

Type of separator

Extraktor 38 - Extraktor 70

(e.g.: MESEP Extraktor 50)

¹ The actual sensitivity depends on various factors. Unfavourable environmental conditions or vibrations can reduce the sensitivity. Conductive test material can also influence the sensitivity. For obliging information please contact our service or sales department. Our service includes product tests in our headquarters.

² Other materials available (glas, antistatic; wear-resistant)

³ Measured with granulate PET - grain dimension 2 - 3 mm.

⁴ Fe → Ferrous / SS → Stainless steel



Special designs & accessories

Designation	Order number
Pneumatic guard	When ordering please add option 45
Wear-resistant model (for very abrasive bulk material)	When ordering please add option 44
Pneumatic cooling	Please specify when ordering

Application example



Three MESEP Extraktor 70 provide for metal-free products.

Metal separator Extraktor



Dimensions

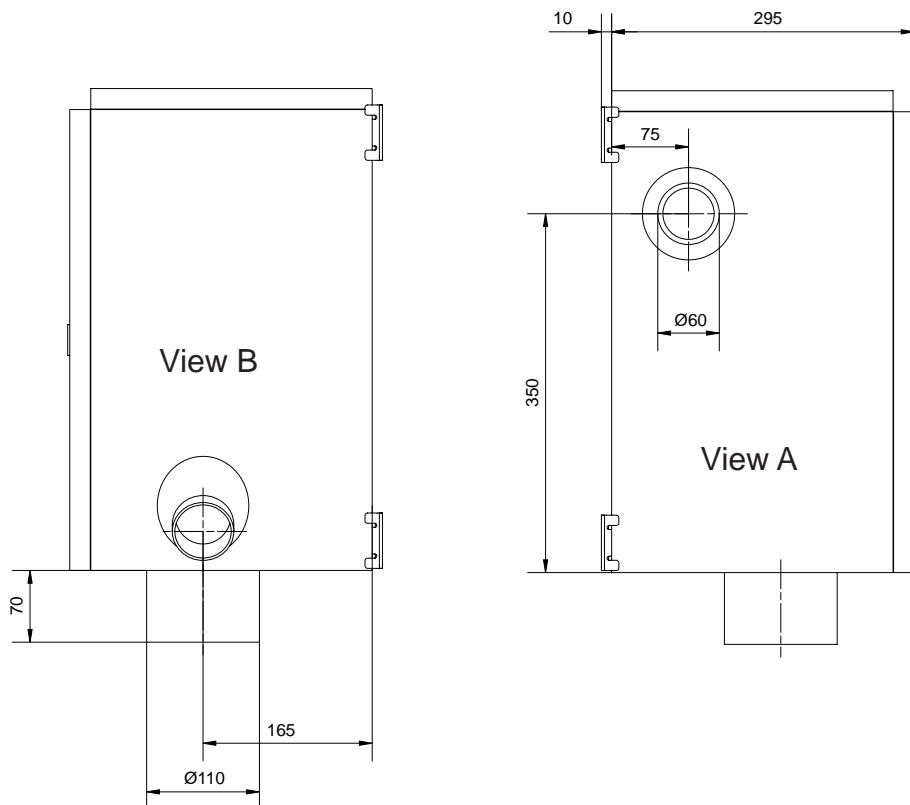
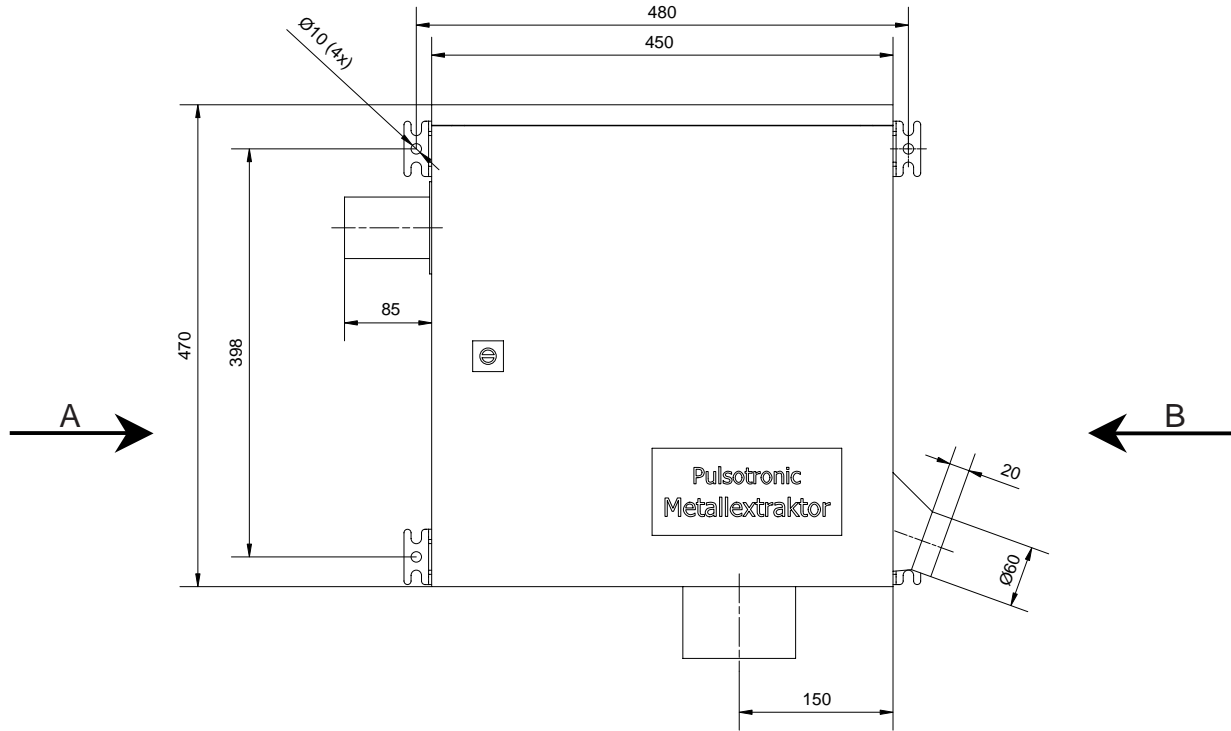

Metal separator Extraktor



p-u-l-s-o-t-r-o-n-i-c

Subject to change without notice!
Rev. 0901

Metal separator M-Pulse / Digital+ / MESEP

GF

Application

Due to its' design this separator can be used in nearly all branches of industry. Because of the stainless steel housing the GF also is appropriate for applications in the food industry. Transmission ports with a maximum diameter of 300 mm allow an extremely high material throughput at maximum sensitivity. This brings advantages for the use in filling systems. The device can be equipped with various separating filters. The operating electronics can be fixed in a maximum distance of 3 meters. By this the GF is easy to handle even in places that are difficult to access.



Metal separator GF

Function

In the upper part of the separator the sensor coil of the metal detector is situated. If metal falls through the sensor the signal is collected and processed by the operating electronics. Subsequently the electronics precisely excites the pulse for piloting the ejection flap. The flap is opened and metal is separated from the product stream. The robust, pneumatic-driven mechanics guarantees durability. Depending on the electronics the function of the ejection can be monitored. Further installations, for example a pressure control device, constantly control the correct function.

Specific Characteristics

- maintenance-free mechanics
- very big transmission ports available
- robust, pneumatic-driven ejection mechanics (optional)
- according to the application different electronics available
- design with or without ejection mechanics available
- protection class IP65
- stainless steel housing
- supporting frame can be integrated in existing constructions



Type ⁴	GF 100	GF 120	GF 150	GF 200	GF 250	GF 300						
Mechanical data												
Height with ejection unit	600 mm	720 mm	850 mm	1.200 mm	1.395 mm	1.605 mm						
Dimensions (W x D)	318 x 450 mm	338 x 450 mm	400 x 502 mm	508 x 615 mm	685 x 800 mm	800 x 940 mm						
Material-ejection unit	stainless steel											
Material-base frame	stainless steel											
Material-protection tube ²	POM											
Conditions of use												
Storage temperature	-10°C .. 60°C											
Operating temperature	0°C .. 50°C											
Protection class	IP54											
Electrical connection	see datasheet of the control unit											
Pneumatic connection	4-6 bar, filtered, free of water and oil; self-sealing-coupling - fitting NW 7,2											
Troughput ³	16.000 l/h	25.000 l/h	43.000 l/h	82.000 l/h	135.000 l/h	200.000 l/h						
Bulk characteristics	free flowing											
Sensitivity¹												
Material - Test pieces ⁵	Fe ⁵	SS ⁵	Fe	SS	Fe	SS	Fe	SS	Fe	SS	Fe	SS
M-Pulse	0,5	1,0	0,7	1,2	0,8	1,4	1,2	2,0	1,5	2,2	1,7	2,5
Digital+	0,5	1,2	0,8	1,4	0,9	1,6	1,3	2,2	1,6	2,5	1,8	2,8
MESEP	not available			3,0	4,0	4,0	5,0	4,0	5,0	n. available		

Ordering code:

Electronic

M-Pulse / Digital+ / MESEP

Type of separator

GF 100 - GF 300

(e.g.: MESEP GF 300)

¹ The actual sensitivity depends on various factors. Unfavourable environmental conditions or vibrations can reduce the sensitivity. Conductive test material can also influence the sensitivity. For obliging information please contact our service or sales department. Our service includes product tests in our headquarters. (all data in mm)

² Other materials available.

³ Measured with granulate PET - grain dimension 2 - 3mm.

⁴ Bigger dimensions and in-between sizes available on request.

⁵ FE → Ferrous / SS → Stainless steel



Delivery programm & accessories

All devices of the GF series are serially delivered without ejection mechanics. Adapted mechanics are separately available for all dimensions. For the connecting of the device to a piping optionally a kit consisting of 3 welding socket pieces, 3 snap closing circlips and 3 cooper gaskets are available. Please inform us about the necessary accessories when placing your order.

Designation	Order number
Pneumatic guard	When ordering please add option 45
Ejector guard (Indicats malfunction of the ejection unit)	When ordering please specify
Ejection flap EX-S-100	08410192011
Ejection flap EX-S-120	08410192012
Ejection flap EX-S-150	08410192013
Ejection flap EX-S-200	08410192014
Ejection flap EX-S-250	08410192015
Ejection flap EX-S-300	08410192016
Ejection flap EX-K-100 wear-resistant w. maintenance opening	08410193022
Ejection flap EX-K-100 wear-resistant w. window	08410193015
Ejection flap EX-K-120 wear-resistant w. maintenance opening	08410193023
Ejection flap EX-K-120 wear-resistant w. window	08410193012
Ejection flap EX-K-150 wear-resistant w. maintenance opening	08410193024
Ejection flap EX-K-150 wear-resistant w. window	08410182013
Ejection flap EX-K-200 wear-resistant w. maintenance opening	08410193025
Ejection flap EX-K-200 wear-resistant w. window	08410182016
Ejection flap EX-K-250 wear-resistant w. maintenance opening	08410193026
Ejection flap EX-K-250 wear-resistant w. window	08410182014
Ejection flap EX-K-300 wear-resistant w. maintenance opening	08410193027
Connecting kit GF / GFC 100 for ejector	08410310000
Connecting kit GF / GFC 120 for ejector	08410310001
Connecting kit GF / GFC 150 for ejector	08410310002
Connecting kit GF / GFC 200 for ejector	08410310004
Connecting kit GF / GFC 250 for ejector	08410310005
Connecting kit GF / GFC 300 for ejector	08410310006
Connecting kit GF / GFC 100 without ejector	08310310007
Connecting kit GF / GFC 120 without ejector	08310310012
Connecting kit GF / GFC 150 without ejector	08310310008
Connecting kit GF / GFC 200 without ejector	08310310009
Connecting kit GF / GFC 250 without ejector	08310310010
Connecting kit GF / GFC 300 without ejector	08310310013



p-u-l-s-o-t-r-o-n-i-c

Dimensions

Metal separator GF

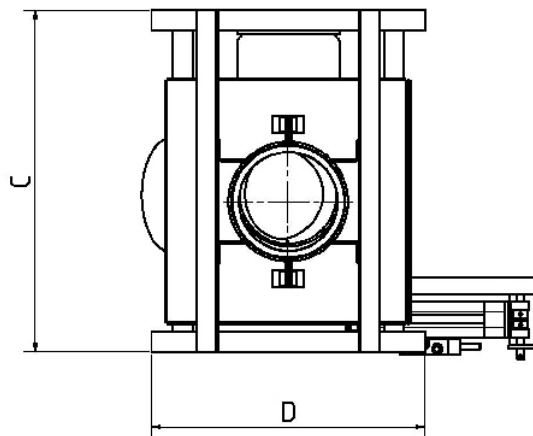
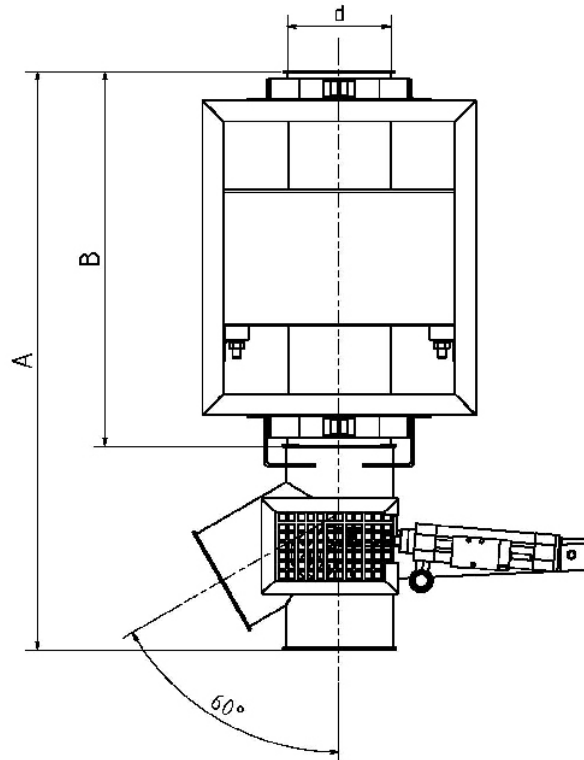

Type	GF 100	GF 120	GF 150	GF 200	GF 250	GF 300
Dimension A	600 mm	710 mm	850 mm	1200 mm	1395 mm	1605 mm
Dimension B	400 mm	490 mm	550 mm	790 mm	935 mm	1100 mm
Dimension C	450 mm	450 mm	500 mm	615 mm	800 mm	940 mm
Dimension D	318 mm	338 mm	400 mm	508 mm	685 mm	800 mm



p-u-l-s-o-t-r-o-n-i-c

Subject to change without notice!
Rev. 0901

Metal separator M-Pulse / Digital+

GFC

Application

The GFC has been developed as a compact version of the GF series for applications where separators from the GF series cannot be used because of restricted space conditions. For this reason the detection performance is lower than that of the GF series. Like the GF series the GFC also has a stainless steel housing and a stable supporting frame. Typical fields of application are on filling systems or separating plants.



Metal separator GFC

Function

In the upper part of the separator the sensor coil of the metal detector is situated. If metal falls through the sensor the signal is collected and processed by the operating electronics. Subsequently the electronics precisely excites the pulse for piloting the ejection flap. The flap is opened and metal is separated from the product stream. The robust, pneumatic driven mechanics guarantees durability. Depending on the electronics the function of the ejection can be monitored. Further installations, for example a pressure control device, constantly control the correct function.

Specific characteristics

- maintenance-free mechanics
- very big transmission ports available
- robust, pneumatic-driven ejection mechanics (optional)
- according to the application different electronics available
- design with or without ejection mechanics available
- protection class IP65
- stainless steel housing
- compact design



Type ⁴	GFC 100	GFC 120	GFC 150	GFC 200	GFC 250	GFC 300						
Mechanical data												
Height with ejection unit (A)	450 mm	530 mm	600 mm	910 mm	1.050 mm	1.095 mm						
Dimension (X x C)	320 x 450 mm	340 x 450 mm	400 x 505 mm	510 x 615 mm	640 x 800 mm	800 x 940 mm						
Nominal width - D	100 mm	120 mm	150 mm	200 mm	250 mm	300 mm						
Material-ejection unit	stainless steel											
Material-base frame	stainless steel											
Material-protection tube ²	POM											
Conditions of use												
Storage temperature	-10°C .. 60°C											
Operating temperature	0°C .. 50°C											
Protection class	IP65											
Electrical connection	see datasheet of the control unit											
Pneumatic connection	4-6 bar, filtered, free of water and oil; self-sealing-coupling - fitting NW 7,2											
Troughput ³	16.000 l/h	25.000 l/h	43.000 l/h	82.000 l/h	135.000 l/h	200.000 l/h						
Bulk characteristics	free falling											
Sensitivity¹												
Material - Test pieces ⁵	Fe	SS	Fe	SS	Fe	SS	Fe	SS	Fe	SS	Fe	SS
M-Pulse	0,7	1,1	1,0	1,4	1,1	1,8	1,6	2,4	2,0	3,1	2,6	4,1
Digital+	0,8	1,3	1,1	1,5	1,2	2,0	1,8	2,5	2,2	3,5	2,8	4,5

Order code:

Electronic Type of separator
 M-Pulse / Digital+ GFC 100 - GFC 300 (e.g.: M-Pulse GFC 150)

¹ The actual sensitivity depends on various factors. Unfavourable environmental conditions or vibrations can reduce the sensitivity. Conductive test material can also influence the sensitivity. For obliging information please contact our service or sales department. Our service includes product tests in our headquarters. (all data in mm)

² Other materials available.

³ Measured with granulate PET - grain dimension 2 - 3mm.

⁴ Bigger dimensions and in-between sizes available on request.

⁵ FE → Ferrous / SS → Stainless steel



Special designs & accessories

All devices of the GFC series are serially delivered without ejection mechanics. Adapted mechanics are separately available for all dimensions. For the connecting of the device to a piping optionally a kit consisting of 3 welding socket pieces, 3 snap closing circlips and 3 cooper gaskets is available. Please inform us about the necessary accessories when placing your order.

Designation	Order number
Pneumatic guard	When ordering please add option 45
Ejector guard (Indicats malfunctions of the ejector unit)	When ordering please specify
Ejection flap EX-S-100	08410192011
Ejection flap EX-S-120	08410192012
Ejection flap EX-S-150	08410192013
Ejection flap EX-S-200	08410192014
Ejection flap EX-S-250	08410192015
Ejection flap EX-S-300	08410192016
Ejection flap EX-K-100 wear-resistant w. maintenance opening	08410193022
Ejection flap EX-K-100 wear-resistant w. window	08410193015
Ejection flap EX-K-120 wear-resistant w. maintenance opening	08410193023
Ejection flap EX-K-120 wear-resistant w. window	08410193012
Ejection flap EX-K-150 wear-resistant w. maintenance opening	08410193024
Ejection flap EX-K-150 wear-resistant w. window	08410182013
Ejection flap EX-K-200 wear-resistant w. maintenance opening	08410193025
Ejection flap EX-K-200 wear-resistant w. window	08410182016
Ejection flap EX-K-250 wear-resistant w. maintenance opening	08410193026
Ejection flap EX-K-250 wear-resistant w. window	08410182014
Ejection flap EX-K-300 wear-resistant w. maintenance opening	08410193027
Connecting kit GF / GFC 100 for ejector	08410310000
Connecting kit GF / GFC 120 for ejector	08410310001
Connecting kit GF / GFC 150 for ejector	08410310002
Connecting kit GF / GFC 200 for ejector	08410310004
Connecting kit GF / GFC 250 for ejector	08410310005
Connecting kit GF / GFC 300 for ejector	08410310006
Connecting kit GF / GFC 100 without ejector	08310310007
Connecting kit GF / GFC 120 without ejector	08310310012
Connecting kit GF / GFC 150 without ejector	08310310008
Connecting kit GF / GFC 200 without ejector	08310310009
Connecting kit GF / GFC 250 without ejector	08310310010
Connecting kit GF / GFC 300 without ejector	08310310013



Dimensions incl. separating filter

Metal separator GFC

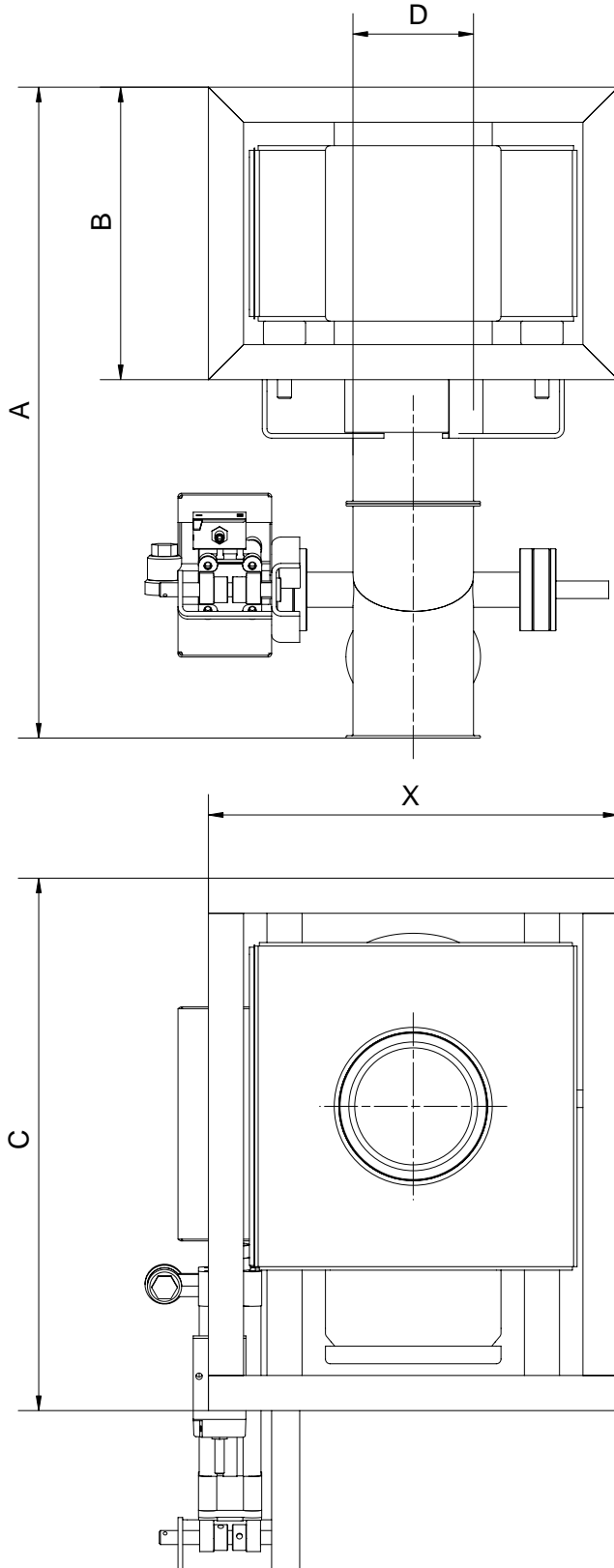

ØD [mm]	A [mm]	B [mm]	C [mm]	X [mm]
100	450	200	450	320
120	530	250	450	340
150	600	250	505	400
200	910	300	615	510
250	1050	390	800	640
300	1095	390	940	800



p-u-l-s-o-t-r-o-n-i-c

Subject to change without change!
Rev. 0901

Metal separator M-Pulse / Digital+ / MESEP

VA

Application

The VA separator is appropriate for applications in the plastics, the pharmaceutical, the chemical or the food industry. The separating mechanics consists of durable stainless steel. Different operating electronics allow adapted solutions for each application. All kinds of free-falling bulk material are detected fast and reliably on metallic contamination. The compact design and transmission ports in different sizes make this separator appropriate for most applications.



Metal separator VA

Function

In the upper part of the separator the sensor coil of the metal detector is situated. If metal falls through the sensor the signal is collected and processed by the operating electronics. Subsequently the electronics precisely excites the pulse for piloting the ejection flap. The flap is opened and metal is separated safely from the product stream. The robust, pneumatic driven mechanics guarantees durability. The functioning of the mechanics can be monitored constantly by several alerters. Thus the device permanently ensures that all metallic pieces have really been separated from the product stream.

Specific characteristics

- maintenance-free mechanics
- different transmission ports available
- robust, pneumatic-driven ejection mechanics
- electronics adapted to the application available
- large range of accessories available
- all devices mechanically compatible



Type	VA 25	VA 35	VA 50	VA 70	VA 100					
Mechanical data										
Aperture - D model MESEP VA	not available	29 mm	45 mm	65 mm	94 mm					
Aperture - D model Digital+ VA model M-Pulse VA	24 mm	29 mm	45 mm	65 mm	94 mm					
Material-ejection unit	stainless steel									
Material-base frame	aluminium / stainless steel									
Material-protection tube ²	phenolic resin									
Payload	max. 50 kg									
Weigth	~ 17 kg									
Conditions of use										
Storage temperature	-10 .. 60°C									
Operating temperature	0 .. 60°C									
Protection class	IP50									
Electrical connection	see datasheet of the control units									
Pneumatic connection	4-6 bar, filtered, free of water and oil; 1/8" - male nippel									
max. drop height of the bulk material	0 .. 600 mm (from top edge)									
Troughput ³	450 l/h	600 l/h	2.000 l/h	5.400 l/h	14.000 l/h					
Sensitivity¹										
Material - test pieces ⁴	FE	SS	FE	SS	FE	SS	FE	SS	FE	SS
M-Pulse	0,15	0,4	0,2	0,5	0,3	0,7	0,5	1,0	0,7	1,2
Digital+	0,2	0,5	0,3	0,6	0,35	0,9	0,6	1,1	0,8	1,3
MESEP	not available	0,5	0,8	0,6	1,2	1,0	1,5	1,3	2,0	

Order code:

Electronic

M-Pulse / Digital+ / MESEP

Type of seperator

VA 25 - VA 100

(e.g.: Digital VA 50)

¹ The actual sensitivity depends on various factors. Unfavourable environmental conditions or vibrations can reduce the sensibility. Conductive test material can also influence the sensibility. For obliging information please contact our service or sales department. Our service includes product tests in our headquarters. (all data in mm)

² Other materials available. (glas, antistatic; wear-resistant)

³ Measured with granulate PET - grain dimension 2 - 4 mm.

⁴ FE → Ferrous / SS → Stainless steel



Special designs & accessories

Designation	Order number
Pneumatic guard	When ordering please add option 45.
Voltage- und pneumatic guard (Flap automatic switches into throw-off position at blackout or falling pressure)	When ordering please add option 40.
Remote terminal (max. 3 m cable length) (only M-Pulse/Digital+)	When ordering please specify
Wear-resistant model (for very abrasive bulk material)	When ordering please add option 44.
Test pieces - certified - Fe/NonFe/SS	on request
Pneumatic cooling (product temperature up to 90°C)	When ordering please specify
Fan cooling (product temperature up to 70°C)	When ordering please specify

Dimensions - MESEP VA 35 .. 100

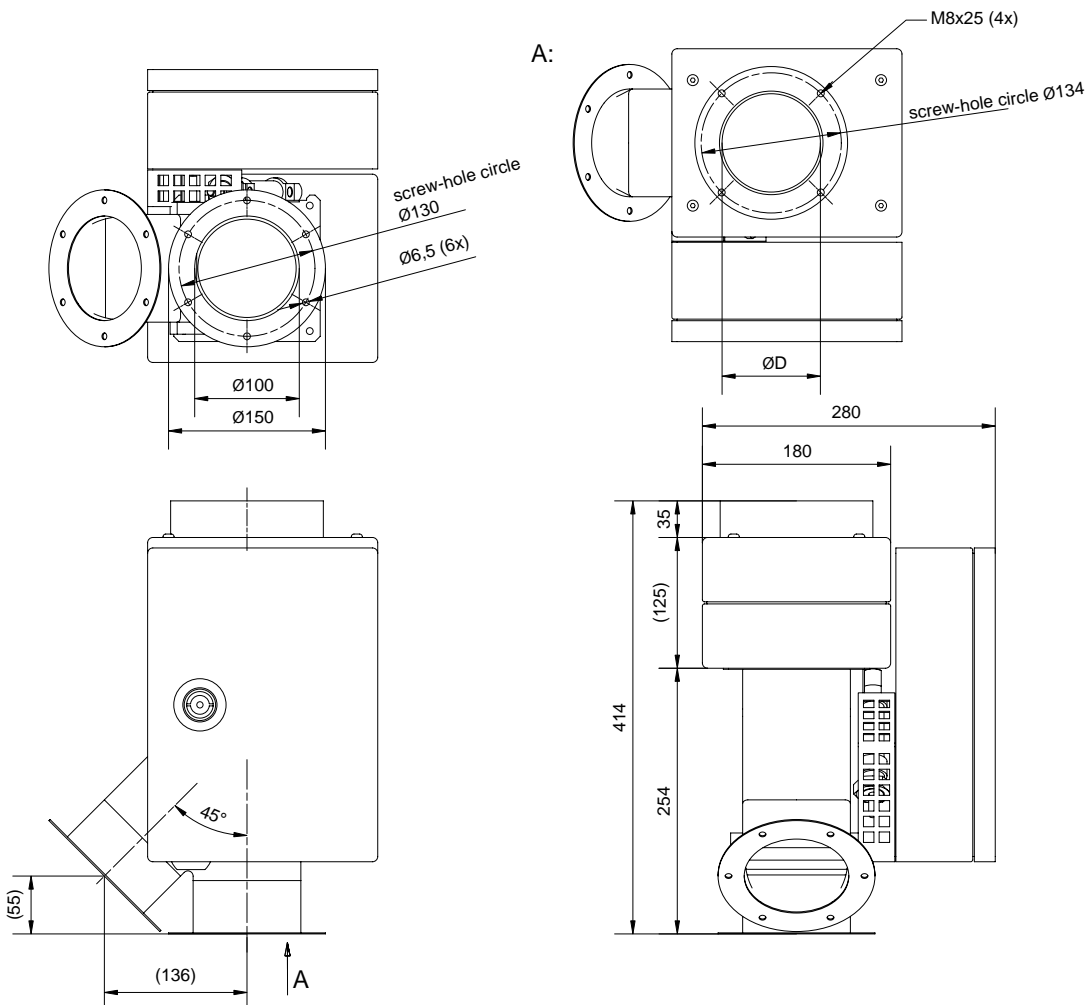

Metal separator VA



p-u-l-s-o-t-r-o-n-i-c

Dimensions

Metal separator VA

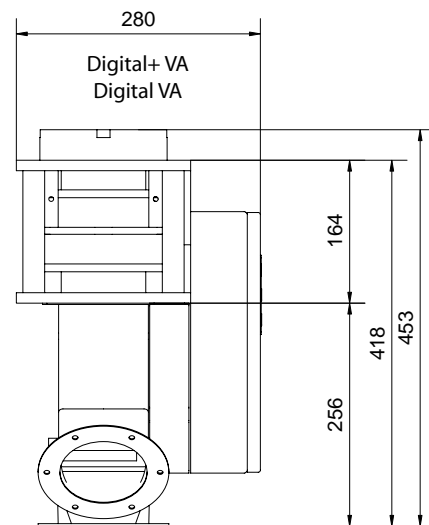
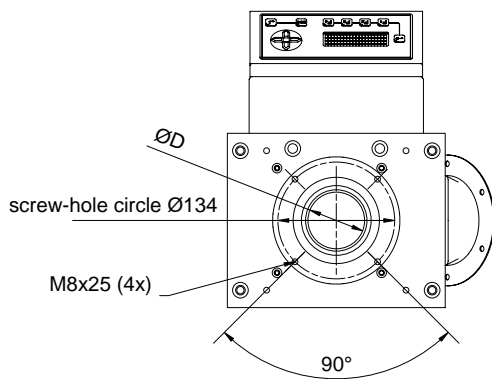
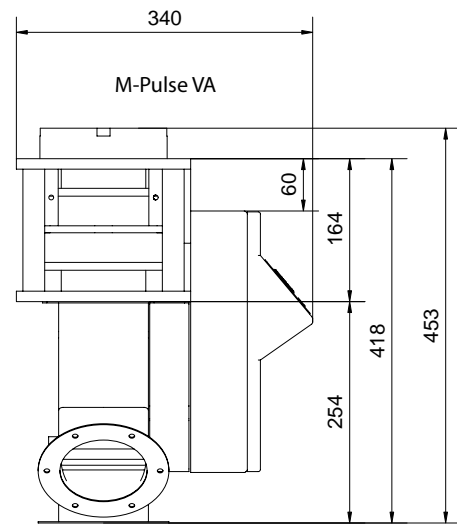
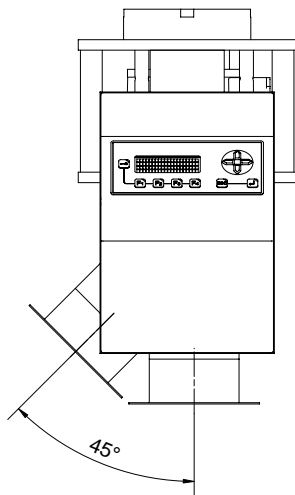
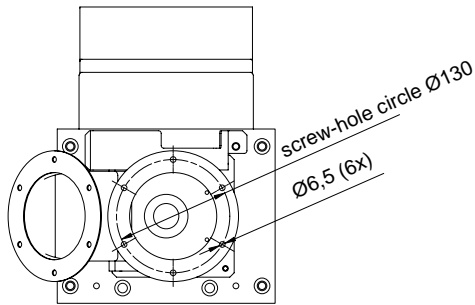



Subject to change without notice!
Rev. 0901

Metal separator M-Pulse / Digital+

Y

Application

Fields of application for the Y series are the plastics and the chemical industry. The separating mechanics allows the separation of metallic objects from free-falling bulk material. The device also is appropriate for applications in which the bulk material is accumulating into the separator. By this for example injection moulding machines can be protected safely from damage caused by metallic contamination. This patented separating technique makes the Y unique. The separator can be applied flexibly in many branches.



Metal separator Y

Function

In the upper part of the separator the sensor coil of the metal detector is situated. If metal falls through the sensor the signal is collected and processed by the operating electronics. Subsequently the electronics precisely excites the pulse for piloting the ejection flap. The flap is opened and metal is separated safely from the product stream. The robust, pneumatic driven mechanics guarantees longevity. The function of the mechanics can be monitored constantly by several alerter. Thus the device permanently ensures that all metallic pieces have really been separated from the product stream.

Specific characteristics

- maintenance-free mechanics
- different transmission ports available
- robust, patented pneumatic-driven ejection mechanics
- appropriate for free-falling bulk material
- large range of accessories available
- all devices mechanically compatible
- compact design
- ejection monitoring



Type	Y 25		Y 35		Y 50		Y 70	
Mechanical data								
Height	370 mm (405 mm with flange)							
Sensor aperture model Digital+ VA und M-Pulse VA	24 mm		29 mm		45 mm		65 mm	
Material-ejection flap	Aluminium							
Material-base fram	Aluminium							
Material-protection tube ²	Phenolic resin							
Payload	max. 150 kg							
Weigth	~ 18 kg							
Conditions of use								
Storage temperature	-10 .. 60°C							
Operating temperature	0 .. 60°C							
Protection class	IP50							
Electrical connection	s. datasheet of the control unit							
Pneumatic connection	4-6 bar, filtered, water- & oilfree; self-sealing-coupling - fitting NW 7,2							
max. drop height of the bulk material	0 .. 600 mm (from top edge)							
Troughput ³	450 l/h		600 l/h		2.000 l/h		5.400 l/h	
Sensitivity¹								
Material - test piece ⁴	FE	SS	FE	SS	FE	SS	FE	SS
M-Pulse	0,15	0,4	0,2	0,5	0,3	0,7	0,5	1,0
Digital+	0,2	0,5	0,3	0,6	0,35	0,9	0,6	1,1

Ordering code:

Elektronic
M-Pulse / Digital+

Separator type
Y 25 - Y 70

(e.g.: Digital+ Y 70)

¹ The actual sensitivity depends on various factors. Unfavourable environmental conditions or vibrations can reduce the sensibility. Conductive test material can also influence the sensibility. For obliging information please contact our service or sales department. Our service includes product tests in our headquarters. (all data in mm)

² Other materials available. (glas, antistatic; wear-resistant)

³ Measured with granulate PET - grain dimension 2 - 4 mm.

⁴ FE → Ferrous / SS → Stainless steel



p-u-l-s-o-t-r-o-n-i-c

Special designs & accessories

Designation	Order number
Pneumatic guard	When ordering please add option 45
Voltage and Pneumatic guard (Flap automatic switches into throw-off position at blackout or falling pressure)	When ordering please add option 40
Remote terminal (max. 3 m)	When ordering please specify
Test pieces - certified - Fe/NonFe/SS (several diameters)	on request
Pneumatic cooling (Product temperature up to 90°C)	When ordering please specify
Fan cooling (Product temperature up to 70°C)	When ordering please specify

Application example

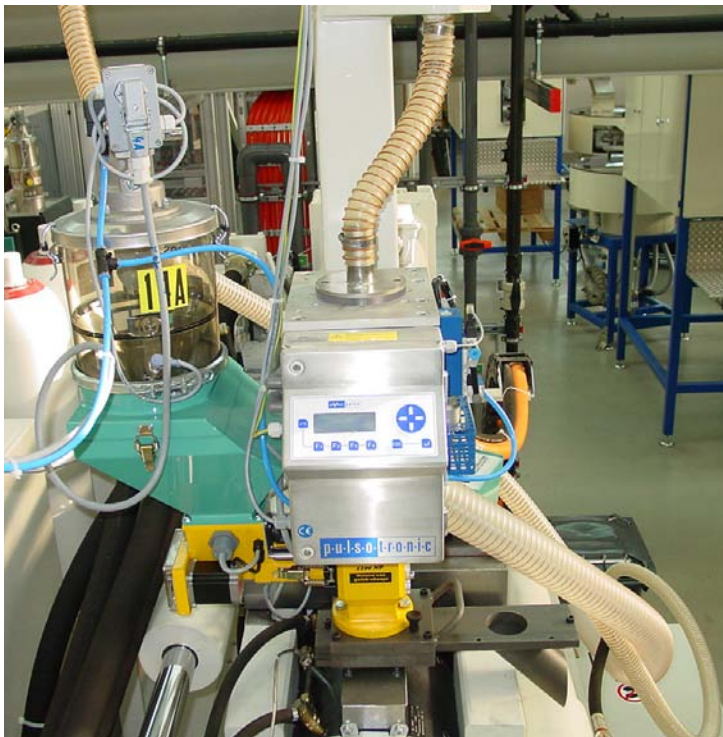

M-Pulse Y for the inspection of granulates in the plastics industry

Metal separator Y



Dimensions

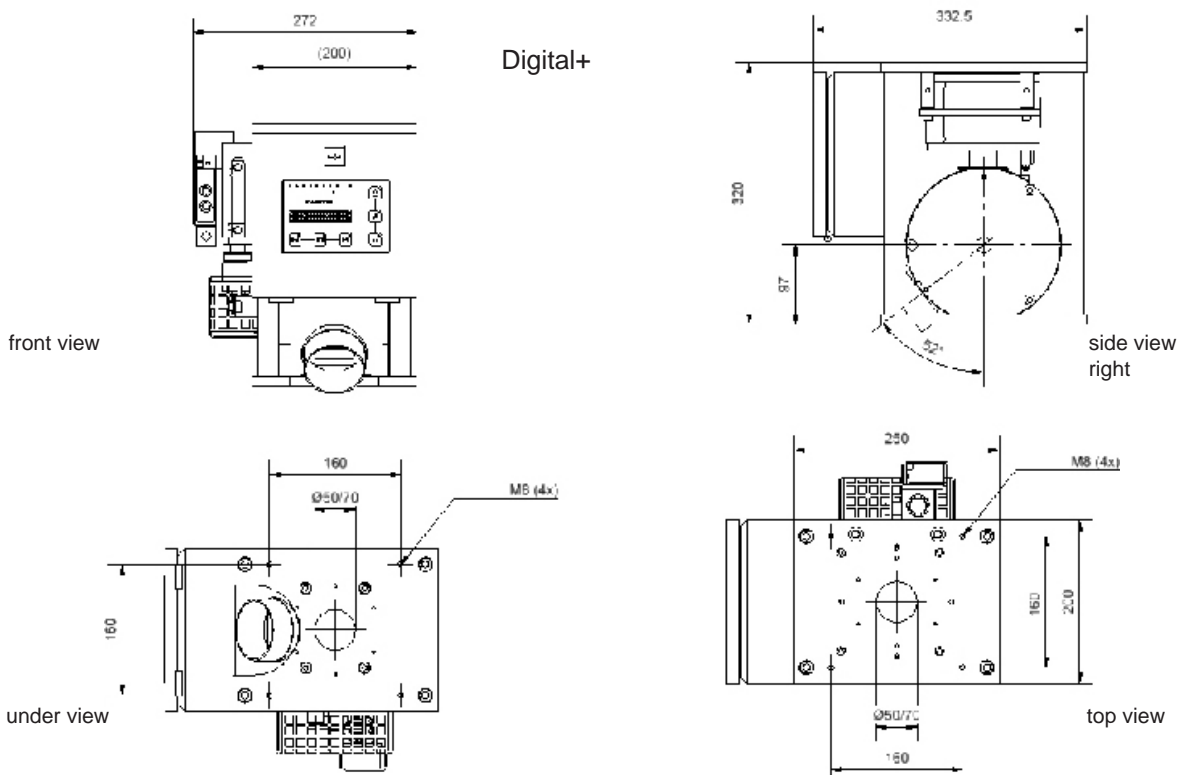
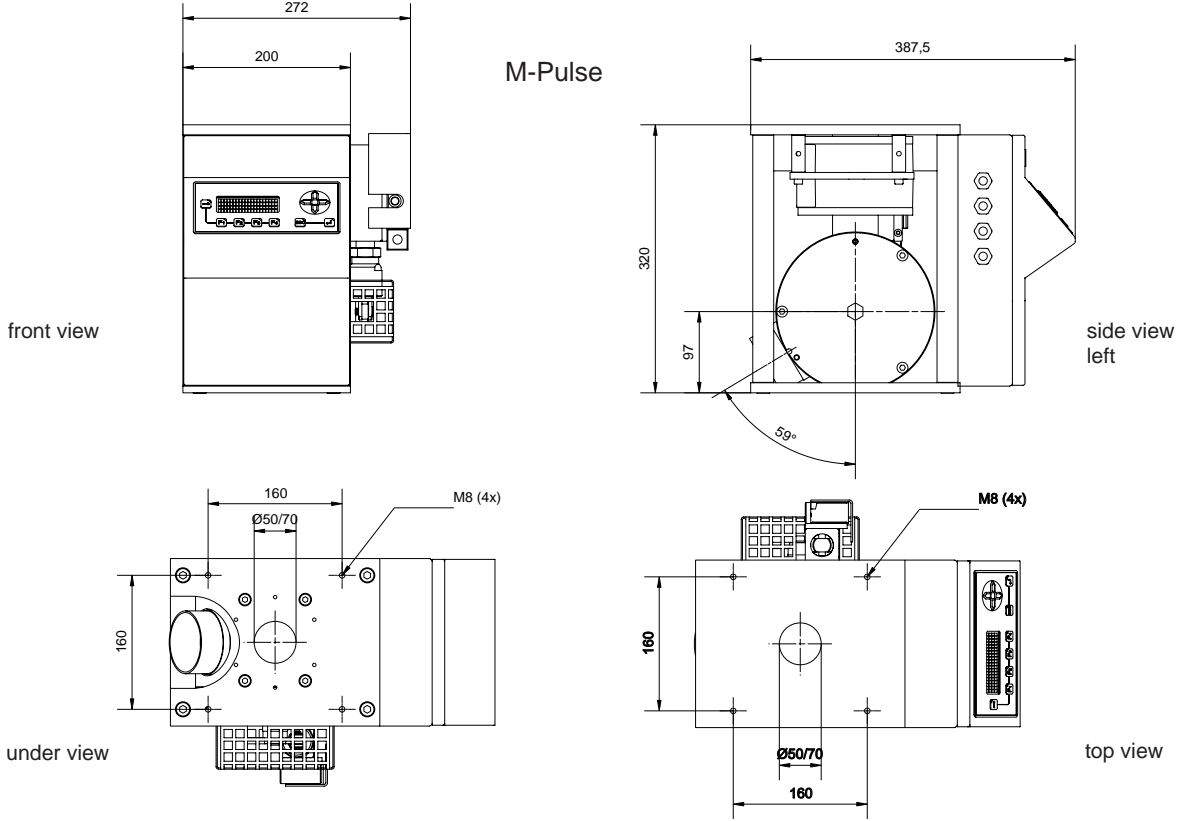



Subject to change without notice!
Rev. 0901

Metal separator M-Pulse / Digital+ / MESEP

SE

Application

This type of separators is used for various applications in the plastics and the chemical industry. All important components of the SE are made of stable die-cast aluminium. Due to this the separator is indestructible and guarantees durability and longevity even under adverse conditions.



Metal separator SE

Function

In the upper part of the separator the sensor coil of the metal detector is situated. If metal falls through the sensor the signal is collected and processed by the operating electronics. Subsequently the electronics precisely excites the pulse for piloting the ejection flap. The flap is opened and metal is separated safely from the product stream. The robust, pneumatic driven mechanics guarantees durability. The function of the mechanics can be monitored constantly by several alerter. Thus the device constantly ensures that all metallic pieces have really been separated from the product stream.

Specific characteristics

- maintenance-free mechanics
- different transmission ports available
- robust, pneumatic-driven ejection mechanics
- large range of accessories available
- all devices are mechanically compatible
- compact design



Type	SE 35		SE 50		SE 70		SE 100	
Mechanical data								
Height	365,5 mm (400 mm with flange)							
Sensor aperture - D model MESEP SE	29 mm		45 mm		65 mm		94 mm	
Sensor aperture - D model Digital+ SE model M-Pulse SE	29 mm		45 mm		65 mm		not available	
Material-ejection flap	stainless steel							
Material-base frame	cast aluminium / stainless steel							
Material-protection tube ²	phenolic resin							
Payload	max. 150 kg							
Weight	~ 21 kg							
Conditions of use								
Storage temperature	-10 .. 60°C							
Operating temperature	0 .. 60°C							
Protection class	IP50							
Electrical connection	see datasheet of the control units							
Pneumatic connection	4-6 bar, filtered, free of water and oil; self-sealing-coupling - fitting NW 7,2							
max. drop height of the bulk material	0 .. 600 mm (from top edge)							
Troughput ³	600 l/h		2.000 l/h		5.400 l/h		14.000 l/h	
Sensitivity¹								
Material - test pieces ⁴	FE	SS	FE	SS	FE	SS	FE	SS
M-Pulse	0,2	0,5	0,3	0,7	0,5	1,0	not available	
Digital+	0,3	0,6	0,35	0,9	0,6	1,1	not available	
MESEP	0,5	0,8	0,6	1,2	1,0	1,5	1,3	2,0

Order code:

Electronic

M-Pulse / Digital+

Type of separator

SE 35 - SE 100

(e.g.: Digital+ SE 70)

¹ The actual sensitivity depends on various factors. Unfavourable environmental conditions or vibrations can reduce the sensibility. Conductive test material can also influence the sensibility. For obliging information please contact our service or sales department. Our service includes product tests in our headquarters. (all data in mm)

² Other materials available. (glas, antistatic; wear-resistant)

³ Measured with granulate PET - grain dimension 2 - 4 mm.

⁴ FE → Ferrous / SS → Stainless steel



Special design & accessories

Designation	Order number
Voltage- und pneumatic guard (Flap automatic switches into throw-off position at blackout or falling pressure)	When ordering please add option 40.
Wear-resistant model (for very abrasive bulk material)	When ordering please add option 44.
Test pieces - certified - Fe/NonFe/SS (several diameters)	on request

Application example



MESEP SE 50 for the inspection of granulates in the plastics industry.

Metal separator SE



Dimensions

Metal separator SE

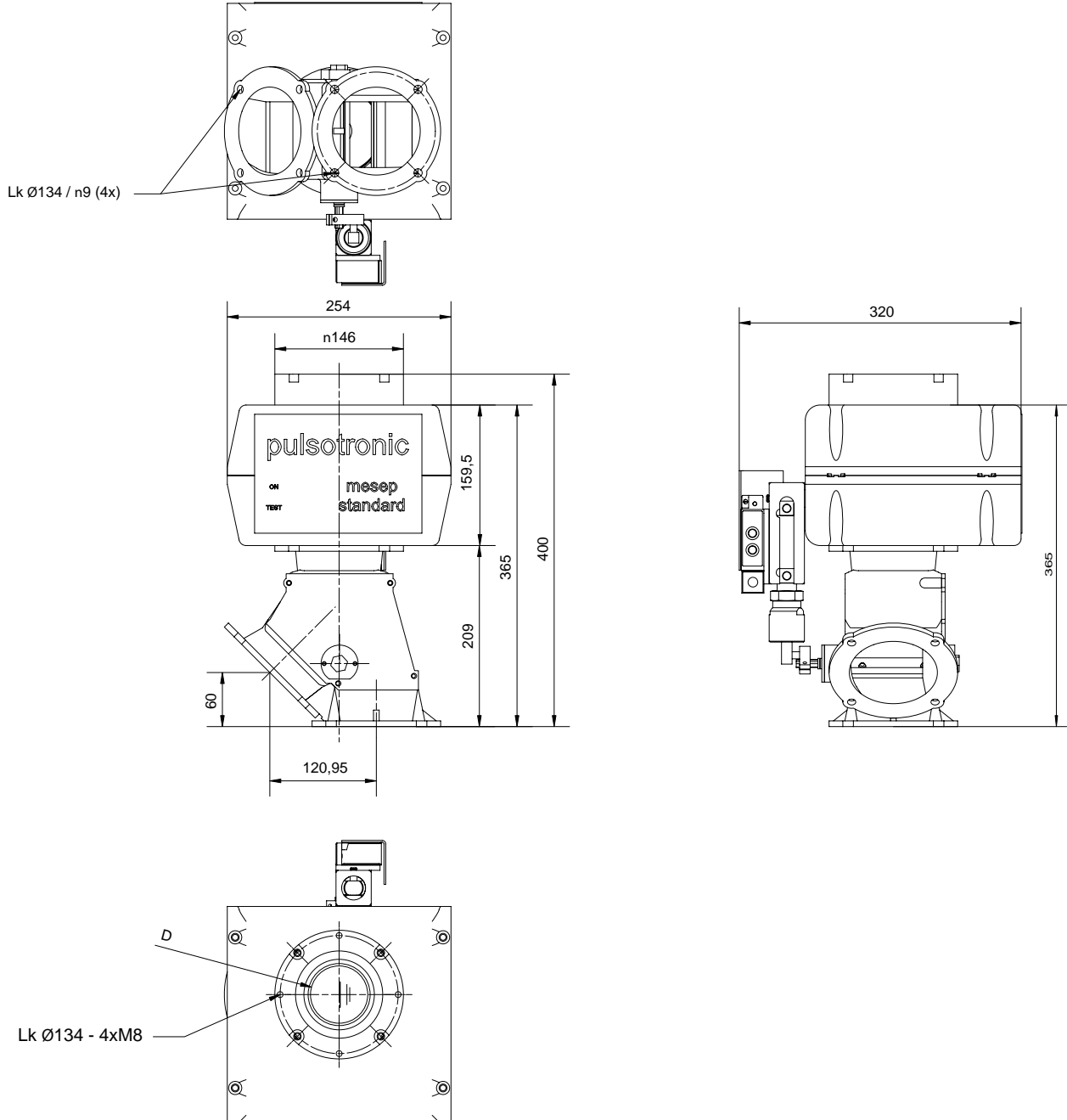

Devices with the operating electronics M-Pulse or Digital+ request an external control electronics which is connected via a 3 m connecting cable with the separator. The dimensions of the electronics are given in the particular data sheets.



p-u-l-s-o-t-r-o-n-i-c

Subject to change without notice!
Rev. 0901

Metal separator MESEP

Classic

Application

The detectors of the Classic series are appropriate for simple applications in all branches of industry. In contrast to many other detectors the separating system does not need compressed air supply. A high capacity electromagnet serves for engine. Due to that the device can be installed and operated nearly on any place. Just connect the detector and start operation.



Metal separator Classic

Function

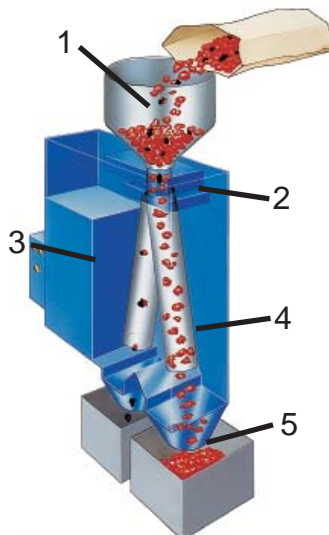

- 1 - feeding hopper
- 2 - sensor
- 3 - electro-magnetic engine
- 4 - movable tube
- 5 - special outlet for metallic residua

The detector is feeded with the test material via an optional hopper or a conveyor line. The sensor coil in the upper part checks it on metallic residua. If the sensor detects metal, he excites a signal directly triggering the electro-magnetic engine. By this a movable tube is powered which separates the metallic pieces from the product stream via a special outlet. Due to the electro-magnetic engine compressed air becomes redundant. Thus the device instantly is ready for operation when the operating voltage is connected.



Type	MESEP Classic 50
Mechanical data	
Dimensions	L x B x H: 340 x 112 x 491 mm (without funnel)
Aperture	40 mm
Material - pendular tube	Stainless steel
Material - housing	Plastic
Material - protection tube	Phenolic resin
Material - ejection flap	Linatex
Weight	13 kg
Conditions of use	
Storage temperature	-10 .. 60°C
Operating temperature	0 .. 60°C
Protection class	IP40
Electrical connection	230 V; 50 Hz oder 115 V; 60 Hz; 3 m cable 3 x 1,5 mm ²
max. drop height of the bulk material	0 .. 1000 mm (from top edge - without funnel)
Troughput ³	1.300 l/h
Sensitivity ¹	Ferrous = 1,0 mm
Ordering information	
Ordering number	230VAC; 50Hz → 08419100000; 115VAC; 60Hz → 08419100031
Funnel (optional)	08410001900

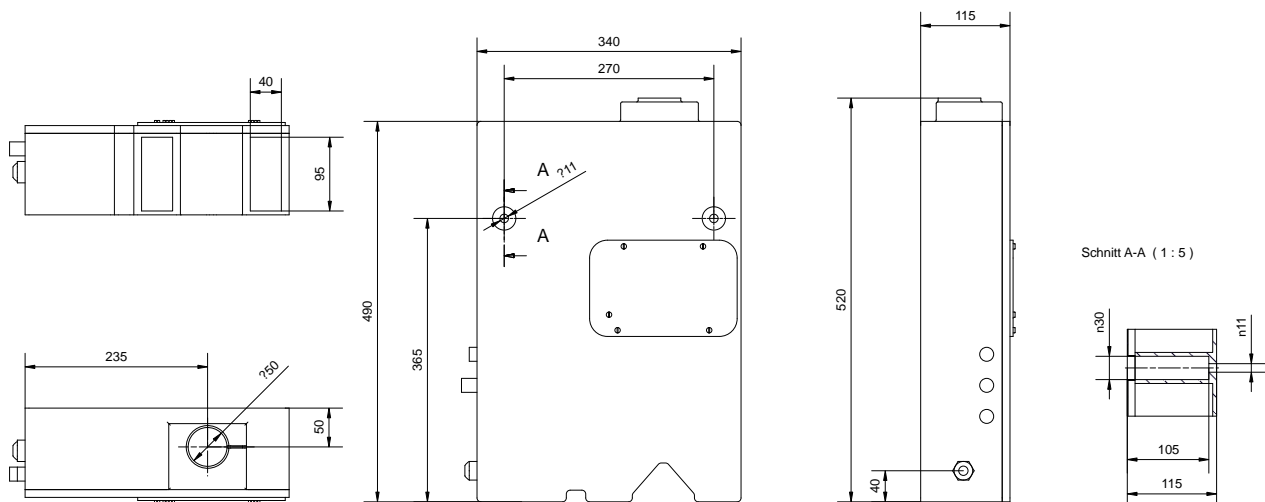

¹ The actual sensitivity depends on various factors. Unfavourable environmental conditions or vibrations can decrease the sensitivity.
³ Measured with granulate PET - grain dimension 2 - 4 mm.



p-u-l-s-o-t-r-o-n-i-c

Subject to change without notice!
Rev. 0901

Metal separator M-Pulse

PH

Application

This separator has been developed for applications making high demands on cleanness. The drive of the separating filter is realised by an electromagnetic rotary drive - compressed air is not required. The PH especially is appropriate for the use in the pharmaceutical industry for the inspection of tablets or the like. A typical application is the integration of the PH next to a tablet press. The device is equipped with two stands and two rolls for movability. The separating filter, the sensor and the electronics are rotatable via a support and height adjustable.



Metal separator PH

Function

The sensor coil of the detector is situated in the upper part of the separator. The test material passes the sensor on a chute. Detected metal is separated via the separating filter. The separating filter is driven by an electromagnet without compressed air. The device is movable and height adjustable. This allows universal and flexible use.

Specific characteristics

- maintenance-free mechanics
- very high sensitivity
- height adjustable and movable
- high-capacity fade-out of product effect
- no need for compressed air for the separating filter
- height adjustable stands for stability
- stainless steel design
- surface electrochemical polished



Type	M-Pulse PH 100 x 50
Mechanical data	
Dimensions	L x B x H: 340 x 112 x 491 mm (without funnel)
Aperture	W x H: 80 x 30 mm
Material	stainless steel (surface electro-chemical polished)
Material - ejector	PMMA
Weight	on request
Conditions of use	
Storage temperature	-10 .. 60°C
Operating temperature	0 .. 60°C
Protection class	IP 53
Electrical connection	230 V; 50 Hz; 100 W; 3 m cable 3 x 1,5 mm ²
Sensitivity¹	
M-Pulse PH	ferrous = 0,3 mm; stainless steel = 0,5 mm
Order information	
Order number	08410810050

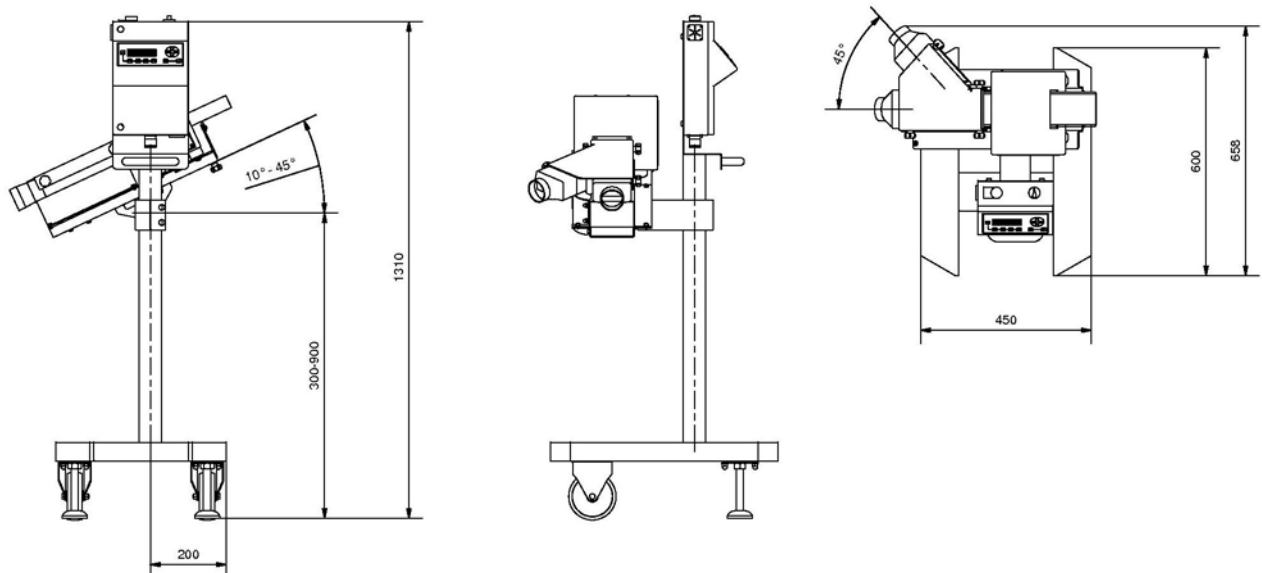

¹ The actual sensitivity depends in various factors. Unfavourable environmental conditions or vibrations can decrease the sensitivity.



Subject to change without notice!
Rev. 0901

Pipe detector M-Pulse

InLine

Application

Devices from the M-Pulse InLine series particularly are used in the food industry for the detection of fluid products and commodities on metallic contamination. Nevertheless they can also be applied in other industrial branches. The detector can be equipped with different ejection valves. Tubes are available in diameters from 40 mm to 150 mm. The connection to the tubes is either realised with Tri-Clamp binders or with milk thread. Thus the detectors can be installed subsequently with little time and effort. The electronics is connected via a 3 m connecting cable. For this reason the device can always be operated easily even when the sensor is used in places that are difficult to access.



M-Pulse InLine

Functioning

The test material passing through the product tube is detected on metallic contamination by the sensor. If metal is detected, this is identified and analysed by the operating electronics. The electronics identifies in real time if there really is metal or if it is just the product effect. Metal is separated via the ejection valve.

Specific characteristics

- design in stainless steel
- protection class IP65
- fade-out of product-effect
- different ejection valves available
- separate control unit
- stable base frame
- individual construction



Type	InLine 40	InLine 50	InLine 65	InLine 80	InLine 100	InLine 125	InLine 150							
Mechanical data														
Material - ejection outlet	stainless steel / POM													
Material - base frame	stainless steel													
Material - product tube	PVDF													
max. delivery pressure	16 bar													
Pipe connection	tri-clamp or milk thread (When ordering please specify!)													
Free pipe diameter	60,5 mm													
Weight ⁴	50 kg	52 kg	55kg	60 kg	63 kg	68 kg	70 kg							
Conditions of use														
Storage temperature	-10 .. 60°C													
Operating temperature	-10 .. 50°C													
max. temperature of the product	-10 .. 120°C													
Protection class	IP 65 oder IP 67 (higher on request)													
Electrical connection	230 VAC; 50-60 Hz; 100 W													
Pneumatic connection	6-8 bar, filtered, free of water and oil; self-sealing-coupling - fitting NW 7,2													
Sensitivity¹														
Material - test pieces ³	Fe	SS	Fe	SS	Fe	SS	Fe	SS	Fe	SS	Fe	SS	Fe	SS
smallest detectable piece [mm]	0,5	1,3	0,7	1,5	0,7	1,5	1,0	1,8	1,2	2,0	1,3	2,2	1,5	2,5
Order information														
Model	IP 65				IP 67									
M-Pulse InLine 40	08410301001				on request									
M-Pulse InLine 50	08410302000				08500180002									
M-Pulse InLine 65	08410303020				08500180003									
M-Pulse InLine 80	08410304000				08500180004									
M-Pulse InLine 100	08410302001				08410302002									
M-Pulse InLine 125	08410302003				on request									
M-Pulse InLine 150	08410302005				on request									

¹ The actual sensitivity depends on various factors. Unfavourable environmental conditions or vibrations can reduce the sensitivity. Conductive test material can also influence the sensitivity. For obliging information please contact our service or sales department. Our service includes product tests in our headquarters.

⁴ Depends on equipment.

³ FE → Ferrous / SS → Stainless steel



Special designs & accessories

Additionally to different ejection valves we offer many other optional components for our InLine detectors. If you have any other requests going beyond the list shown below, please contact our sales department.

Accessories	
Butterfly valve f. InLine 50	08410502011 (model with tri-clamp-connection)
Butterfly valve f. InLine 65	08410503011 (model with tri-clamp-connection)
Butterfly valve f. InLine 80	08410504011 (model with tri-clamp-connection)
Butterfly valve f. InLine 100	08410505011 (model with tri-clamp-connection)
Bogen valve f. InLine 50	08410502012 (model with tri-clamp-connection)
Bogen valve f. InLine 50	08410502013 (model with thread DN50 - 78 x 1/6")
Bogen valve f. InLine 65	08410503012 (model with tri-clamp-connection)
Bogen valve f. InLine 65	08410503018 (model with thread DN65 - 95 x 1/6")
Ejection valve f. InLine 40	08410501002 (model with thread DN40 - 65 x 1/6")
Ejection valve f. InLine 50	08410502001 (model with thread DN50 - 78 x 1/6")
Ejection valve f. InLine 65	08410503001 (model with thread DN65 - 95 x 1/6")
Ejection valve f. InLine 80	08410504001 (model with thread DN80 - 110 x 1/4")
Ejection valve f. InLine 100	08410505001 (model with thread DN100 - 130 x 1/4")
Ejection valve f. InLine 125	08410502004 (model with thread DN125 - 160 x 1/4")
Ejection valve f. InLine 150	on request (model with thread DN150 - 190 x 1/4")

M-Pulse InLine



Example

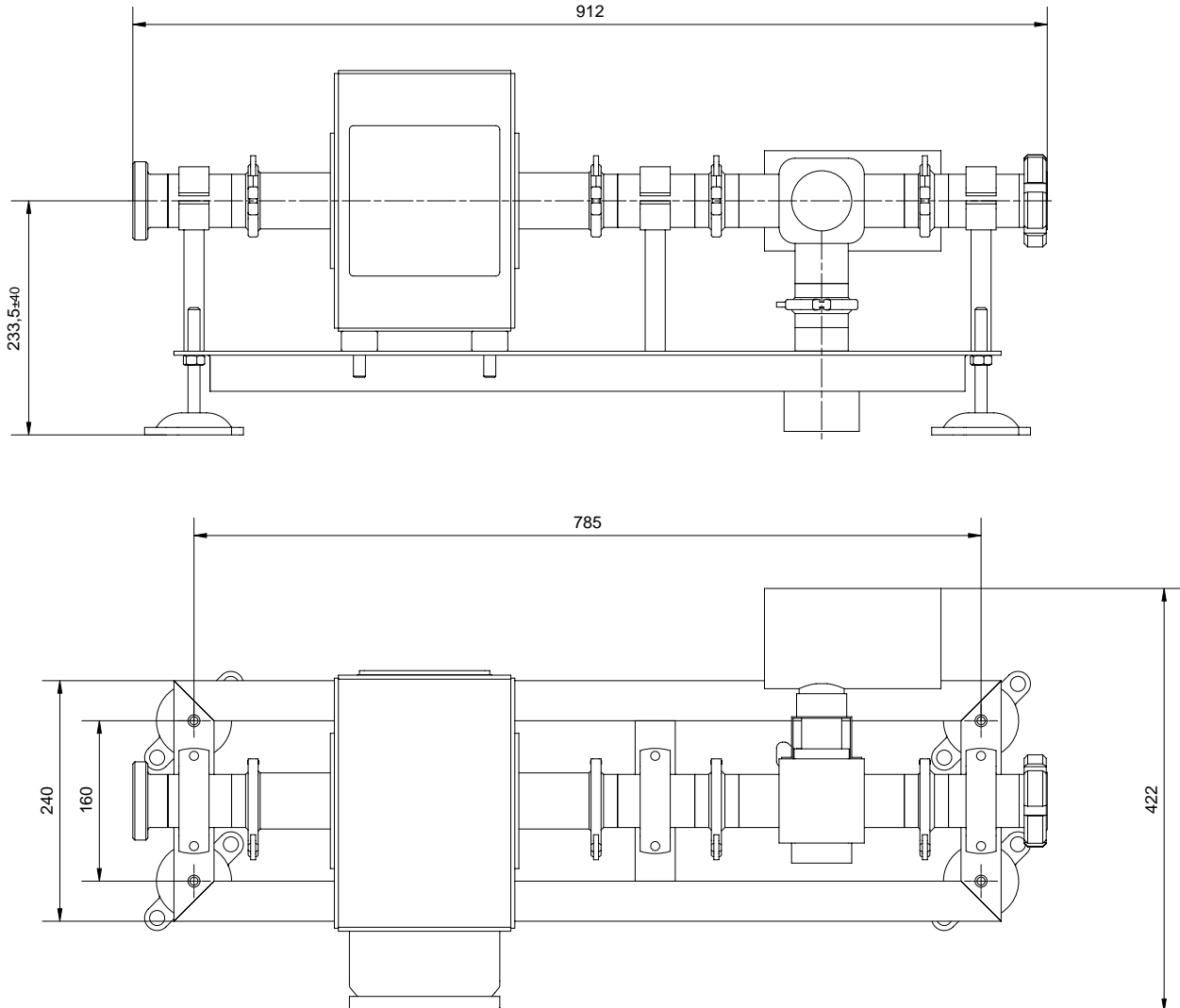

M-Pulse InLine

The drawings show one possible design. Each device will be manufactured individually according at request. Along with different ejection valves you choose among different types of tubes. The frame construction will be adapted according to your specifications in order to allow a smoothly integration in your existing plants.



Subject to change without notice!
Rev. 0901

Pipe detector M-Pulse

InFlex

Application

This type of detectors especially is used for the manufacture of sausage meat in filling machines. Other high-viscosity products of the food industry, e.g. marzipan, can also be detected on finest metallic residua. The high-strength product tubes resist to pressures of maximum 80 bar. The connection is realised by RD80 screwings. The device is height-adjustable and mobile. By this it can be connected to all common filling machines (e.g. Handtmann; Frey; Vemag, Risco, Rex). On request we provide devices with linking engine for direct connection of wring-off units. To your requirements adapted ejection valves for the separation of metal are available.



M-Pulse InFlex

Functioning

The test material passing through the product tube is detected on metallic contamination by the sensor. If metal is detected, this is identified by the operation electronics. Metal is separated via the ejection valves (optional). The electronics also is able to interrupt the filler in order to remove the contamination manually.

Specific characteristics

- design in stainless steel
- height adjustable and mobile
- protection class IP65
- fade-out of product effect
- available with wring-off engine
- ejection valves optionally available
- control of filling at the detection of metal



Type	M-Pulse InFlex 65	
Mechanical data		
Inlet height	850 .. 1.200 mm (Stand adjustable in height with gas pressure spring)	
Material-ejection unit	stainless steel / POM	
Material-base frame	stainless steel	
Material-product tube	POM	
max. delivery pressure	80 bar	
Pipe connection	RD 80 x 1/4"	
Free pipe diameter	60,5 mm	
Weight	~50 kg	
Conditions of use		
Storage temperature	-10 .. 60°C	
Operating temperature	-10 .. 50°C	
Protection class	IP65	
Control cable for filling machine	including cable and connector (When ordering please specify your filling machine)	
Electrical connection	230 VAC; 50-60 Hz; 100 W	
Pneumatic connection ³	6-8 bar, filtered, free of water and oil; self-sealing-coupling - fitting NW 7,2	
Sensitivity¹		
Material - test pieces	ferrous	stainless steel
smallest detectable piece	0,5 mm	1,0 mm
Order information		
M-Pulse InFlex 65	08410303010	
M-Pulse InFlex 65 with gearbox for Handtmann	08500180000	
M-Pulse InFlex 65 with gearbox for Vemag	08500180005	
Ejection outlet ²	08410503002	

¹ The actual sensitivity depends on various factors. Unfavourable environmental conditions or vibrations can reduce the sensitivity. Conductive test material can also influence the sensitivity. For obliging information please contact our service or sales department. Our service includes product tests in our headquarters.

² Available only for devices without wring-off engine.

³ Compressed air only necessary in combination with ejection valves.



p-u-l-s-o-t-r-o-n-i-c

Subject to change without notice!
Rev. 0901

Inspection system (highest quality) Belt conveyor & detector M-Pulse BD

HQ

Application

The conveyor belts HQ in combination with our metal detectors of the BD series result in a high-sensitivity and highly reliable device for the detection and the separation of metal. All devices are manufactured individually according to your requirements. The construction as well as the manufacturing of the HQ series are completely realised in our headquarters. Due to this fact and to our expertise we provide for the optimum solution for each of your assignments. Our plants are used in all branches of industry. Particularly they serve for the inspection of singular goods or bulk material. The robust design in stainless steel stands for longevity and comes up to strict hygienic standards.



Inspection system HQ

Specific characteristics

- speed-controlled, high-capacity engine
- high-performance fade-out of product effect
- various separating attachments available
- belt available in different materials and designs
- special designs (curved conveyors, elevating conveyors etc.)
- height adjustable and optionally mobile
- clean and solid treatment
- customised designs



Function

The conveyor belt leads the test material through the metal detector. The detector scans the products and analyses the data in real-time. Powerful processors allow a high-precision fade-out of the product effect. Furthermore interfering influences as for example vibrations can effectively be eliminated. Even at high velocities the device works reliably and precisely. If metal is detected in the test material, there are different possibilities for the separation of the contamination. The easiest way is to get the conveyor belt stopped automatically and to remove the contamination manually. After that the conveyor belt restarts at the push of a button. For highly automated manufacturing plants we recommend a separating system that works automatically. Thereby the metallic contamination is detected precisely by a light barrier. Thus the position of the contamination in the product stream is clear and the metallic residues can be separated. If there are several products in the sensor range at the moment of the detection of metal, the high-performance technology allows the automatic exclusion of all questionable products. There are different principles for separating the contamination:

1. Push

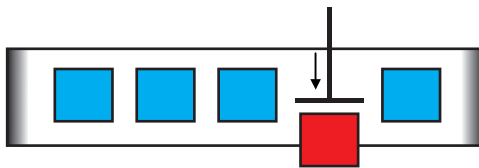

2. Blow-out

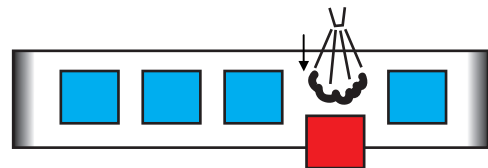

3. Rotary arm

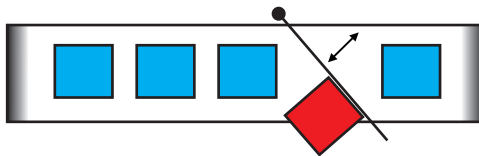

4. Telescopic conveyor

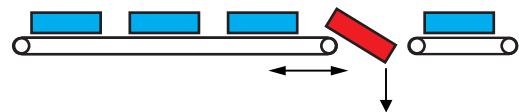

5. Drop flap

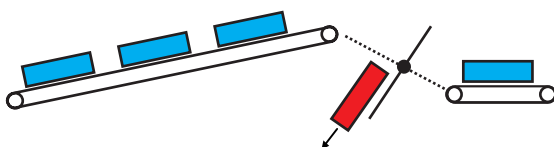

6. Fold-away conveyor

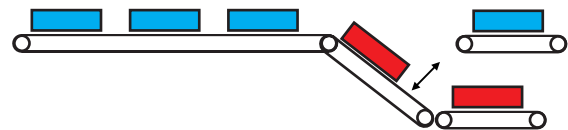



Equipment

All conveying plants are serially equipped with an adjustable engine. The conveyor belt, an open link chain conveyor, is even and without curves. It possessed height adjustable stands (± 50 mm) without ear. The power switch, the emergency stop button and the start/stop button are serially integrated. The entire frame construction as well as the switch cabinet are made of stainless steel and are fully capsuled (IP 65). Information concerning the sensitivity are given in the data sheets of the BD series. Equipment for the control electronics you will find in the data sheets of the electronics M-PULSE.

Accessories & options

Next to separating filters there are many other additional components for our conveyor plants. If you have any other requests going beyond the list shown below, please contact our sales department.

Designation
safe for contaminated products
design: elevating conveyor
design: curved conveyor
belt material - link chain closed
belt material - polyurethan
design: belt conveyor
signal light - alarm for metal detection
signal light - performance test
signal transmitter - alarm for metal detection
side guidance fixed
side guidance adjustable
fill level control for safe
compressed air monitoring
ejection monitoring
protection class IP67
guide pulley with fixation
stands with ears
touch panel



I. General provisions

1. The Supplier's General Terms and Conditions of Sale and Delivery apply exclusively to the legal relationships between Pulsotronic Anlagentechnik GmbH (Supplier) and the Customer. We hereby explicitly object to any of the Customer's terms and conditions that may contradict or deviate from our terms and conditions of delivery. Our terms and conditions of delivery apply even if we deliver to the Customer without reservations even though we are aware that his terms and conditions deviate and contradict our conditions. Our terms and conditions of delivery also apply to all future legal transactions with the Customer.

2. Our written Order Confirmation is exclusively relevant for the scope, type and method as well as any deadlines for deliveries. Our quotations are always subject to change without notice, inasmuch as they are not explicitly stated to be binding. The contract only materializes upon our written confirmation and in accordance with its contents or delivery/service. In the event of doubt, silence on our behalf in response to a quotation indicates a negative answer.

3. We reserve the proprietary rights and copyrights without reservations for any estimations of costs, drawings or other documents (referred to herein as Documents). The documents may only be made accessible to third parties after our prior written agreement and must be returned to us immediately upon demand. Clauses 1 and 2 apply to the Customer's documents accordingly. These may however be made accessible to such third parties who we have delegated to make such deliveries.

4. Part deliveries are permitted, provided they are reasonable to the Customer.

II. Prices and payment terms

1. The prices are quoted ex works, excluding insurance and packaging, plus the respectively applicable legal rate of value added tax. Ancillary services will be invoiced separately.

2. If we have taken over the setup or assembly and nothing to the contrary is agreed, the Customer will be responsible for all the necessary ancillary costs such as travel expenses, costs for the transportation of the commodities required for the setup or assembly, as well as the personal luggage and the per diems, in addition to the agreed payment.

3. An order is a binding quotation. We can accept this quotation at our discretion within 2 weeks by responding with our Order Confirmation or by sending the ordered goods to the Customer within this period.

4. Our invoices are due for payment without deductions within 30 days of the date of invoicing. If the Customer defaults on payment, we are entitled to demand late payment interest in the amount of 10% over the prime rate. If we can prove the damages caused by the delay are higher, we are entitled to enforce these. The Customer is however entitled to prove to us that we suffered no loss or a much lower loss as a result of the default.

5. Payments shall be made to our designated account without any transaction charges.

6. Deductions require special written agreement.

7. The Customer can only offset his own demands against us, if these have been legally ascertained, are undisputed or have been acknowledged by us.

8. A right of retention can only be exercised by the Customer if the counterclaim is based on an individual contract from the same legal relationship.

9. Payments are always applied against the oldest debt.

10. Bills of exchange and cheques are only considered as payment after they are cashed. Payments by bills of exchange must be agreed in advance in writing. Discount costs and other costs from bills of exchange go to the account of the Customer and must be paid immediately plus the respectively valid rate of value added tax.

11. If the Customer makes no payments when they are due, then we can discontinue working on ongoing orders and demand immediate prepayment for all orders that are not yet completed or demand corresponding collateral security. If the Customer does not comply with our demands for advance payment or collateral security, we are entitled to withdraw from the contract and to invoice the Customer for the costs incurred to date.

12. Payment with a discharging effect can only be made to representatives or agents if the representative or agent has written proof of his collection authorization.

III. Reserved ownership

1. The delivery items (goods subject to retention of title) remain our property until full performance of any entitlements we may have against the Customer as a result of the entire business relationship. In the event that the value of all the security interests to which we are entitled exceeds the amount of all the secured entitlements by more than 20%, we will release a corresponding portion of the security interests at our discretion at the Customer's request.

2. During the existence of the reserved ownership, the Customer is prohibited from mortgaging or transferring the goods by way of security; reselling to resellers during the course of normal business is only permitted under the condition that the ownership only passes to the Customer, once he has fulfilled his payment obligations. The Customer assigns all the outstanding moneys in the amount of the final invoice total of our demands which he would receive as a result of a resale to his customers or third parties to us at this time. This applies irrespective of whether the object of sale is resold without or after further processing. We are authorized to collect these demands ourselves. The Customer's right to collect the demands revocably continues to exist even after collecting the demands. The Customer obliges himself to notify us of the names of the third-party debtors and to supply us with all other information and documents so that we are in a position to implement the demands assigned to us.

3. The processing, handling or alteration of our goods is always carried out on our behalf. In the event of processing, installing, joining or intermixing

with other items that are not our property, we acquire joint ownership in the new item based on the percentage invoice value between our goods and the other goods at the time of processing, joining or intermixing. The same conditions apply to the item that is produced as a result of the processing as well as for the conditionally supplied object of sale.

4. The Customer must notify us immediately in the case of levies of execution, confiscations or other court orders or official action by third parties. The Customer will be responsible for any costs incurred by us as a result of such measures.

5. In the case of breaches of duty by the Customer, especially payment defaults, we have the right of redemption; the Customer is obliged to give up possession. This also applies if the Customer has already installed the subject matter of the contract. The Customer will then be responsible for all the costs of redemption and the utilization of the goods including fair utilization costs. The redemption or enforcement of the reserved ownership or the seizing of the goods with reserved ownership by us does not represent the cancellation of the contract, unless we have explicitly stated this is the case.

IV. Delivery deadlines and delays

1. Observing the agreed delivery deadlines is conditional on the timely receipt of all the documents, required permits and approvals, especially with regard to drawings, as well as the observance of the agreed payment terms and other obligations that are to be supplied by the Customer. If these conditions are not fulfilled punctually, the deadlines will extend themselves appropriately. This does not apply if we are responsible for the delay. The burden of proof here is with the Customer.

2. If the non-observance of the period can be attributed to Acts of God (e.g. mobilization, war, unrest or similar events such as strikes or lockouts) or other circumstances for which we cannot be held responsible, the deadlines extend themselves appropriately.

Occurrences of Acts of God, which completely or partially prevent Pulsotronic from fulfilling its contractual obligations, release us from fulfilling the contract in question until the Act of God is eliminated. The inability to be adequately supplied with raw or auxiliary materials as well as the inability to procure modes of transport is considered equal to an occurrence of an Act of God.

3. In the case of supply delays, the Customer can demand damages for every completed week of the delay in the amount of 0.5%, provided he can prove that he has suffered damages as a result of this, but he may not demand more than 5% of the price for that part of the deliveries which could not expediently be taken into operation as a result of the delay. If we are able to prove that the Customer's damages caused by the delay are lower than those specified, then we are only obliged to reimburse the incurred damage.

4. Claims for damages by the Customer, which exceed the limits specified in Para 3, are excluded in all cases of late delivery, even after the period of grace set for us has expired. This does not apply, if, in cases of intent, gross negligence or damages involving health effects, human injury or loss of life, where liability is mandatory. Within the framework of the legal provisions, the Customer can only withdraw from the contract if we can be held responsible for the delay in delivery. A change in the burden of proof to the disadvantage of the Customer is not connected to the aforementioned rulings.

5. The Customer is obliged to explain within an appropriate period on demand whether he is withdrawing from the contract due to the delivery delay or if he insists on delivery.

6. If the shipping or delivery is delayed at the request of the Customer by more than one month after being notified the goods are ready to be shipped, the Customer can be charged 0.5% of the price of the subject matter of the deliveries for every started month, but no more than a total of 5% as storage charges. Notwithstanding this, the contracting parties must prove the storage costs were higher or lower.

V. Passing of the risk

1. The risk of accidental loss and accidental deterioration passes over to the Customer in the case of deliveries without setup or assembly upon handover of the item to the forwarding agent, freight carrier or other persons or agents designated to perform the shipment. Deliveries are insured by us against the usual transportation risks at the request and expense of the Customer.

2. In the case of deliveries with setup or assembly at the Customer's location, the danger passes upon the acceptance at the Customer's site or after the successful completion of a trial operation, inasmuch as this was agreed.

3. If the consignment, delivery, commencement, setup or assembly, acceptance in his own operation or the trial operation is delayed for reasons for which the Customer is responsible, or if the Customer has an acceptance delay due to other reasons, then the risk passes to the Customer.

VI. Setup and Assembly

The following provisions apply for the setup and assembly, provided nothing to the contrary is agreed in writing:

1. The Customer must promptly take over and provide the following at his expense:

a) All earthwork, construction and other industry-unrelated additional work including all the specialist and non-skilled workers, construction materials and tools required for this,

b) All implements and materials required for the assembly and commissioning such as scaffolding, lift equipment and other equipment, fuel and lubricants,

c) Energy and water at the location including connections, heating and illumination,

d) Sufficiently large, suitable, dry and lockable rooms and appropriate working and accommodation space suitable for the assembly staff at the assembly location to store machinery parts, apparatus, materials, tools, etc; in addition, the Customer must undertake measures to protect the property of his Supplier and the assembly staff at the construction site, similar to what he must undertake to protect his own property,



- e) Protective clothing and devices, which are required as a result of the special circumstances at the assembly location.
- Before commencing with the assembly work, the Customer must provide the necessary details concerning the location of any hidden power, gas, water lines or similar systems as well as the necessary structural details without this needing to be requested.
 - Before commencing with the setup or assembly, all the provisions and items required in order to commence with the work must be in existence at the setup or assembly location and all the preparatory work must have advanced to such a stage before commencement of the setup work that the setup or assembly can commence in accordance with the agreement and without any interruptions. Approach routes and the setup or assembly site must be level and cleared.
 - If the setup, assembly or commissioning is delayed due to circumstances for which the Supplier cannot be held responsible, the Customer must bear the costs for the waiting time and additional travel costs for the Supplier or the assembly staff.
 - The Customer must confirm the duration of the assembly staff's working time as well as the completion of the setup, assembly and commissioning work without delay to the Supplier on a weekly basis.
 - If the Supplier demands the delivery be accepted after completion, then the Customer must take care of this within two weeks. If this does not occur, then acceptance will be considered to have taken place. Acceptance is also considered to have occurred if the delivery has been put into operation, after completion of an agreed test phase, if necessary.

VII. Acceptance

The Customer may not refuse the acceptance of deliveries due to slight faults.

VIII. Quality defects

The Customer's quality defect claims are conditional on the Customer having properly complied with his duty to examine and give notice of defects in accordance with § 377 HGB.

We are liable for quality faults, as follows:

- All those parts or services, which reveal a quality defect within the limitation period must be repaired, re-supplied or re-performed at no charge at our discretion provided the cause of the defect already existed at the time the risk was transferred. Initially, we must be given the opportunity for supplementary performance within an appropriate period of time. If the supplementary performance fails, the Customer may withdraw from the contract or reduce the payment, irrespective of any entitlements for compensation for damages in accordance with Section XI.
- Quality defect claims are statute-barred after 12 months: This does not apply inasmuch as the law according to § 438 Sub-section 1 No 2 (structures and items for structures), § 479 Sub-section 1 (claims under the right of recourse) and § 634a Sub-section 1 No 2 (construction defects) BGB stipulates longer periods and in cases of damages involving health effects, human injury or loss of life, breaches of duty due to intent or gross negligence by us or malicious concealment of a defect. The legal regulations on interrupting work flow, restraint and the recommencement of deadlines remains unaffected.
- The Customer must immediately report any quality faults to us in writing.
- In the case of quality complaints, the Customer's payments may be held back to an extent that is appropriate to the quality faults that have occurred. The Customer may only hold back payments, if a quality complaint is enforced for which there is no doubt about its validity. If the quality complaint proves to be wrong, we are entitled to demand the Customer reimburse us for any expenses that are incurred.
- No warranty claims are allowed for negligible deviations from the agreed appearance and workmanship, for natural wear or damages, which occur after the transfer of risk as a result of faulty or careless handling, excessive strain, inappropriate equipment, defective construction work, inappropriate foundation soil or because of special external influences, which are not a prerequisite according to the contract, as well as for non-reproducible software errors. If the Customer or a third party performs improper modifications or repair work, then no warranty claims can be made for these or for the ensuing consequences.
- The Customer's claims for the expenses required for the purpose of subsequent performance, especially transportation, mileage costs, labour and material costs, are excluded, inasmuch as the expenses increase because the object of the delivery was subsequently taken to another location than the Customer's establishment, unless the transfer/transportation corresponds with its intended use.
- The Customer's claims against us under the company's right of recourse according to §478 BGB only exist inasmuch as the Customer has not reached any additional agreements with his Customer concerning legal warranty claims. § 478 Sub-section 2 BGB, Section 6 applies to the extent of the Customer's recourse entitlements against us.
- Moreover, Section XI (Other claims for damages) applies to claims for damages. Advanced claims by the Customer or claims due to a quality defect against us or persons employed performing an obligation for whom we are vicariously liable that are different from those governed in Sub-section VIII are excluded.

IX. Industrial property rights and copyrights; defects of title

- If nothing to the contrary is agreed, we are only obliged to provide the delivery free of industrial property rights and third party copyrights (referred to as Property Rights in the following) in the country of the delivery location. If a third party asserts justified claims against the Customer due to violations of industrial property rights for deliveries supplied us and used in accordance with the contract, we will be liable to the Customer within the period specified in Section VIII, Para 2:

- We will either impose a right of use at our discretion and at our expense for the deliveries concerned, or modify these so that the industrial property right are not infringed or supply a replacement. If this is not possible for us under appropriate conditions, the Customer is entitled to the legal rights of recourse or the right to a reduction in price due to a defect.

b) Our obligation to provide compensation for damages complies with Section XI.

- The aforementioned obligations only exist if the Customer immediately notifies us about any claims being enforced by third parties via us, does not acknowledge an infringement and if the right to undertake all further defensive measures and conciliatory negotiations is reserved for us. If the Customer ceases using the product for damage mitigation or other important reasons, he is obliged to inform third parties that no acknowledgement of a breach of a property right is involved with this discontinuance of use.

2. The Customer's claims are excluded inasmuch as he is responsible for the property right violation.

- Furthermore, the Customer's entitlements are excluded inasmuch as the property right violation was not caused by special requirements by the Customer, as a result of unforeseen use or because the delivery was modified or has been used together with products that were not supplied by us. In the event of special requirements, the Customer bears the responsibility for the risk of property right violations; no duty of information or legal duty to give advice with regards to us exists. In the event of property right violations due to utilization, the Customer bears the burden of proving that we were able to foresee such an utilisation.

4. In the event of property right violations, the provisions in Section VIII, Paras 1, 4 and 7 apply to the Customer's entitlements governed in Para 1a.

5. In the event of the existence of miscellaneous defects of title, the clauses in Section VIII apply accordingly.

6. Advanced claims by the Customer or claims due to defects of title against us or persons employed performing an obligation for whom we are vicariously liable, which are different from those governed in this section, are excluded.

X. Impossibility; Contract adaptation

- In the event of an impossibility for which we can be held responsible, the Customer is entitled to demand compensation for damages. Claims for damages by the Customer are limited to 5% of the value of that part of the delivery, which cannot be put into the intended operation as a result of the impossibility. This limitation does not apply to cases where liability is mandatory in the event of intent or gross negligence. No change in the burden of proof to the disadvantage of the Customer is involved with this. The Customer's right to withdraw from the contract is not affected by this.

- If unforeseen events in terms of Section IV Para 2 considerably change the importance or the contents of the delivery or have a considerable effect on our operation, the contract will be adjusted fittingly taking good faith into consideration. Inasmuch as this is not economically justifiable, we have the right to withdraw from the contract. The Supplier will notify the Customer that he is exercising the right to withdraw from the contract immediately after recognising the implications of the occurrence. The legal transaction will then be reversed in accordance with the legal regulations, so that the Customer has no entitlements to damages. The right of withdrawal continues to exist even if an extension of the delivery period is initially agreed with the Customer.

XI. Other claims for damages

- Claims for damages and expenses by the Customer (referred to herein as claims for damages), irrespective of their legal grounds, especially because of breaches of duties as a result of the contractual obligation or unauthorized actions, are excluded.

- This does not apply in cases of mandatory liability in accordance with the product liability legislation, in the event of intent, gross negligence, and damages involving health effects, human injury or loss of life or because of breaches of fundamental contractual obligations. The claims for damages for the breaching of fundamental contractual obligations is limited to the foreseeable damages typical for the contract provided the liability is not the result of damages which relate to health effects, human injury or loss of life. A change in the burden of proof to the disadvantage of the Customer is not connected to the aforementioned rulings.

- Inasmuch as the Customer is entitled to claims for damages in accordance with this Section, these claims are statute-barred upon the expiry of the limitation period that is in effect in accordance with Section VIII Para 2. The legal statutes of limitation apply for claims for damages according to the product liability legislation.

XII. Place of performance, legal venue and applicable law

- The place of performance and sole legal venue is the location in which the Customer has his place of business, provided the Customer is a businessman. The Supplier is also entitled to bring an action against the Customer at his general legal venue.

- German material law, excluding the UN Convention on contracts for the international sale of goods (CISG), applies to the legal relationships in conjunction with this contract.

XIII. Severability Clause

The invalidity of individual provisions of these Terms and Conditions of Sale and Delivery does not affect the validity of the remaining provisions. In place of the invalid provisions, a provision which comes closest to the economic implications of the invalid provision will take its place.



Headquarters Niederdorf

Pulsotronic-Anlagentechnik GmbH
Neue Schichtstraße 7
D-09366 Niederdorf

Tel.: +49 37296 9383-500

Fax: +49 37296 9383-501

info@pulsotronic-anlagentechnik.de
www.pulsotronic-anlagentechnik.de

AUSTRALIA

Comtec IPE The Parrington Group Pty. Ltd.
22/198-222 Young Street
Waterloo NSW 2017
Phone: 00 61 / 08 37 44 633
Fax: 00 61 / 08 29 90 892

AUSTRIA

Magnet Works Vertriebs GmbH
Estermannstraße 8a
A-4020 Linz
Phone: 00 43 / 73 27 78 780
Fax: 00 43 / 73 27 78 78 10

BELGIUM / LUXEMBOURG

Verco S.P.R.L.
Rue de Woeringen 9
1000 Bruxelles
Phone: 00 32 / 25 13 76 69
Fax: 00 32 / 25 11 03 53

CZECH REPUBLIC

Bibus s.r.o.
Videnska 125
63927 Brno
Phone: 00 42 / 05 47 12 53 24
Fax: 00 42 / 05 47 12 53 10

DENMARK

Scancomp
Odensevej 43
DK 5260 Odense SV
Phone: 00 45 / 66 11 29 89
Fax: 00 45 / 66 11 29 63

FRANCE

Verco - France
32, Rue Commandant Fuzier
69003 Lyon
Phone: 00 33 / 47 28 44 105
Fax: 00 33 / 47 86 26 023

GREAT BRITAIN

Arrowquint -
Brian Bayes /Kevin Horne.
Unit 15D, Site A
Sywell Aerodrome Industrial Estate
Northampton NN6 0BN
Phone: 00 44 / 84 50 65 54 55
Fax: 00 44 / 84 50 65 54 56

HONGKONG

Trillion Machinery Holding Co. Ltd.
Room. 26, 20/F. Metro Centre
Phase II, 21 Lam Hing Street
Kowloon Bay
Hongkong
Phone: 00 85 / 22 70 70 555
Fax: 00 85 / 22 70 70 588

ISRAEL

HOR-TAL
Marketing Production & Services Co.Ltd.
18,Hayetzira St., Kiryat Arie
P.O.B. 3265 Israel
Phone: 00 972 / 39 26 93 45
Fax: 00 972 / 39 22 95 65

ITALY

Calamit SRL
Via Romagna 35
20093 Cologno Monzese (MI)
Phone: 00 39 / 02 25 39 14 45
Fax: 00 39 / 02 25 39 14 09

ITALY

Tritecnica Srl
Viale Lazio 26
20135 Milano
Phone: 00 39 / 02 54 194 1
Fax: 00 39 / 02 55 010 474
P. IVA 007 5495 01552

Malaysia

Enge Plas Automation SDN BHD
Industrial Park, Jalan Tun Dr. Ismail
70200 Seremban, Negri Sembilan
Phone: 00 60 / 606 76 12 333
Fax: 00 60 / 606 76 14 133

POLAND

Labotek Polska
ul. Poznanska 1
63-005 Kleszczewo
Phone: 00 48 / 61 64 16 667
Fax: 00 48 / 61 64 17 667

SINGAPORE

Enge Plas Automation (S) Pte Ltd
51 Ubi Ave 1, #01-19
Paya Ubi Industrial Park,
Singapore 408933
Phone: 00 65 / 6343 1911
Fax: 00 65 / 6343 1123

SWITZERLAND

Dr. Brehm Ingenieurbüro
Lettenstr. 2/4
6343 Rotkreuz
Phone: 00 41 / 41 79 04 164
Fax: 00 41 / 41 79 04 303

TAIWAN

Dwo & Tom Enterprise Co., Ltd.
Majestic Trading Co., Ltd.
Fl. 3, No. 168
Nanking East Road, Sec. 5, Taipei
Phone: 00 886 / 2 27 68 23 23
Fax: 00 886 / 2 27 68 33 23

TURKEY

Depar Ltd. Sti.
Büyükdere Cad. Altinova Apt. No: 54
Kat: 6 Daire: 6
34387 Medciyeköy Istanbul
Phone: 00 90 / 21 22 88 58 66
Fax: 00 90 / 21 22 66 01 53

USA

Foremost Machine Builders, Inc.
23 Spielmann Road, P.O. Box 644
Fairfield, New Jersey 07006
Phone: 00 1 / 97 32 27 07 00
Fax: 00 1 / 97 32 27 73 07